

## Overview

The KEMET GTX plastic case filters cover single-phase EMC requirements with a wide variety of characteristics. By using nanocrystalline core material, these filters achieve excellent attenuation characteristics in a compact size. In addition, 6 different combinations of Y capacitors can be selected to support various inverter topologies. These filters are compact and lightweight due to its high mechanical density.

## Applications

- Industrial equipment
- General purpose inverter
- Medical equipment
- Commercial equipment

## Benefits

- Single-phase 250 VAC
- Current range from 6 to 30 A
- Nanocrystalline core material
- Selection of Y capacitors combinations
- Compact and lightweight
- Operating temperature range from -25°C to +105°C
- UL, c-UL, and TÜV approved
- RoHS compliant



## Part Number System

GTX-	2	060-	Y00
Series	Phase	Rated Current (A)	Class Y Capacitors
GTX	2 = Single-phase	0x0 = x A xx0 = xx A	Y00 = C <sub>Y1</sub> : None, C <sub>Y2</sub> : None Y02 = C <sub>Y1</sub> : None, C <sub>Y2</sub> : 2,200 pF Y03 = C <sub>Y1</sub> : None, C <sub>Y2</sub> : 3,300 pF Y0X = C <sub>Y1</sub> : None, C <sub>Y2</sub> : 10,000 pF Y22 = C <sub>Y1</sub> : 2,200 pF, C <sub>Y2</sub> : 2,200 pF YXX = C <sub>Y1</sub> : 10,000 pF, C <sub>Y2</sub> : 10,000 pF

Алматы (7273)495-231  
Ангарск (3955)60-70-56  
Архангельск (8182)63-90-72  
Астрахань (8512)99-46-04  
Барнаул (3852)73-04-60  
Белгород (4722)40-23-64  
Благовещенск (4162)22-76-07  
Брянск (4832)59-03-52  
Владивосток (423)249-28-31  
Владикавказ (8672)28-90-48  
Владимир (4922)49-43-18  
Волгоград (844)278-03-48  
Вологда (8172)26-41-59  
Воронеж (473)204-51-73  
Екатеринбург (343)384-55-89

Россия +7(495)268-04-70

Иваново (4932)77-34-06  
Ижевск (3412)26-03-58  
Иркутск (395)279-98-46  
Казань (843)206-01-48  
Калининград (4012)72-03-81  
Калуга (4842)92-23-67  
Кемерово (3842)65-04-62  
Киров (8332)68-02-04  
Коломна (4966)23-41-49  
Кострома (4942)77-07-48  
Краснодар (861)203-40-90  
Красноярск (391)204-63-61  
Курск (4712)77-13-04  
Курган (3522)50-90-47  
Липецк (4742)52-20-81

Казахстан +7(7172)727-132

Магнитогорск (3519)55-03-13  
Москва (495)268-04-70  
Мурманск (8152)59-64-93  
Набережные Челны (8552)20-53-41  
Нижний Новгород (831)429-08-12  
Новокузнецк (3843)20-46-81  
Ноябрьск (3496)41-32-12  
Новосибирск (383)227-86-73  
Омск (3812)21-46-40  
Орел (4862)44-53-42  
Оренбург (3532)37-68-04  
Пенза (8412)22-31-16  
Петрозаводск (8142)55-98-37  
Псков (8112)59-10-37  
Пермь (342)205-81-47

Киргизия +996(312)96-26-47

Ростов-на-Дону (863)308-18-15  
Рязань (4912)46-61-64  
Самара (846)206-03-16  
Саранск (8342)22-96-24  
Санкт-Петербург (812)309-46-40  
Саратов (845)249-38-78  
Севастополь (8692)22-31-93  
Симферополь (3652)67-13-56  
Смоленск (4812)29-41-54  
Сочи (862)225-72-31  
Ставрополь (8652)20-65-13  
Сургут (3462)77-98-35  
Сыктывкар (8212)25-95-17  
Тамбов (4752)50-40-97  
Тверь (4822)63-31-35

Тольятти (8482)63-91-07  
Томск (3822)98-41-53  
Тула (4872)33-79-87  
Тюмень (3452)66-21-18  
Ульяновск (8422)24-23-59  
Улан-Удэ (3012)59-97-51  
Уфа (347)229-48-12  
Хабаровск (4212)92-98-04  
Чебоксары (8352)28-53-07  
Челябинск (351)202-03-61  
Череповец (8202)49-02-64  
Чита (3022)38-34-83  
Якутск (4112)23-90-97  
Ярославль (4852)69-52-93

## Dimensions – Millimeters

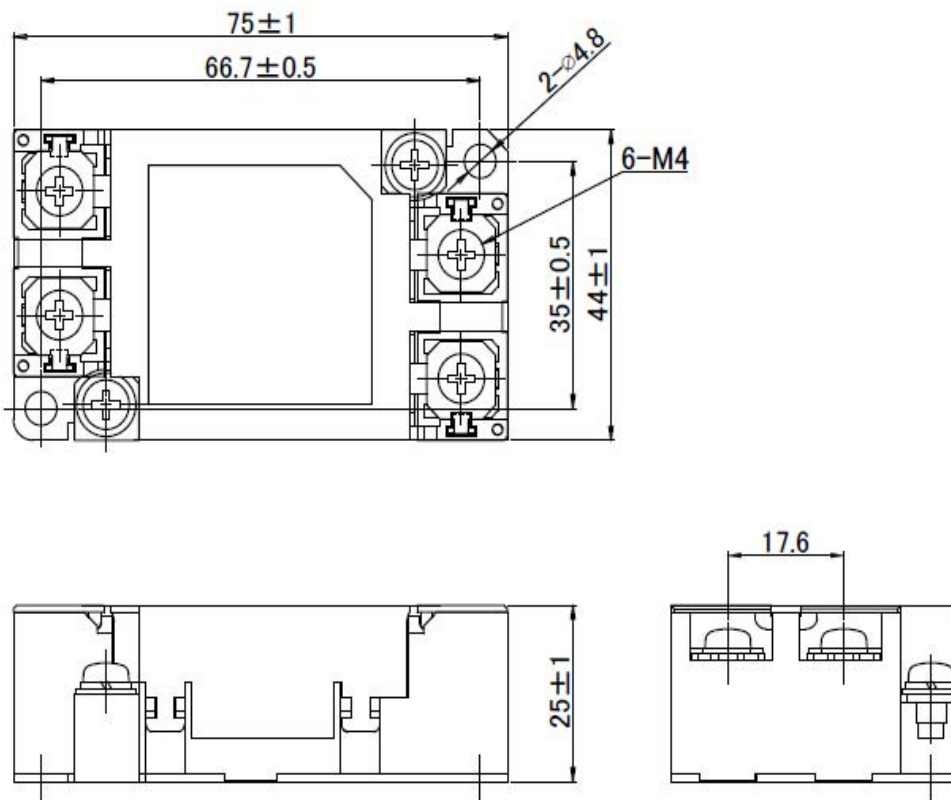

## Environmental Compliance

KEMET GTX EMI-RFI Filters comply with EU RoHS Directive 2011/65/EU and (EU) 2015/863. Products that fall under the exemptions listed in below table are also included.



Part Number	RoHS Compliant	RoHS Exemption Code
GTX	Yes	7(c)-I

Code	Exemption
7(c)-I	Electrical and electronic components containing lead in a glass or ceramic other than dielectric ceramic in capacitors, e.g. piezoelectronic devices, or in a glass or ceramic matrix compound

## Approvals

Certification Body	File Number	Part Number
UL/cUL	E506378	All GTX EMI-RFI Filters
TÜV Rheinland Japan Ltd.	R50457083	All GTX EMI-RFI Filters

## Performance Characteristics

Item	Performance Characteristics
Rated Voltage	250 VAC (50/60 Hz) and 560 VDC <sup>1</sup>
Rated Current Range	6 – 30 A
Withstanding Voltage	1,500 VAC (1 minute, line to ground)
Insulation Resistance	300 MΩ minimum at 500 VDC (1 minute, line to ground)
Leakage Current Range	0.01 – 4.60 mA maximum at 250 V/60 Hz
Input/Output Terminal Type	Screw
Operating Temperature Range	-25°C to +105°C (refer to derating curve) (not including self temperature rise)

<sup>1</sup> Rated DC voltage is not allowed to approval standards.

### Table 1 – Ratings & Part Number Reference

Part Number	Phase	Rated Voltage AC/DC <sup>1</sup> (V)	Rated Current AC/DC (A)	Leakage Current at 250V/60 Hz (mA) Maximum	Temperature Rise <sup>2</sup> (K) Maximum	Operating Temperature Range	Terminal Type	Approval	Weight (g)
GTX-2060-Y00	Single-phase	AC250/DC560	6	0.01	60	-25°C to +105°C	Screw	UL, c-UL, and TÜV	123
GTX-2060-Y02	Single-phase	AC250/DC560	6	0.50	60	-25°C to +105°C	Screw	UL, c-UL, and TÜV	123
GTX-2060-Y03	Single-phase	AC250/DC560	6	0.75	60	-25°C to +105°C	Screw	UL, c-UL, and TÜV	124
GTX-2060-Y0X	Single-phase	AC250/DC560	6	2.30	60	-25°C to +105°C	Screw	UL, c-UL, and TÜV	125
GTX-2060-Y22	Single-phase	AC250/DC560	6	1.00	60	-25°C to +105°C	Screw	UL, c-UL, and TÜV	125
GTX-2060-YXX	Single-phase	AC250/DC560	6	4.60	60	-25°C to +105°C	Screw	UL, c-UL, and TÜV	127
GTX-2100-Y00	Single-phase	AC250/DC560	10	0.01	60	-25°C to +105°C	Screw	UL, c-UL, and TÜV	121
GTX-2100-Y02	Single-phase	AC250/DC560	10	0.50	60	-25°C to +105°C	Screw	UL, c-UL, and TÜV	122
GTX-2100-Y03	Single-phase	AC250/DC560	10	0.75	60	-25°C to +105°C	Screw	UL, c-UL, and TÜV	122
GTX-2100-Y0X	Single-phase	AC250/DC560	10	2.30	60	-25°C to +105°C	Screw	UL, c-UL, and TÜV	124
GTX-2100-Y22	Single-phase	AC250/DC560	10	1.00	60	-25°C to +105°C	Screw	UL, c-UL, and TÜV	123
GTX-2100-YXX	Single-phase	AC250/DC560	10	4.60	60	-25°C to +105°C	Screw	UL, c-UL, and TÜV	126
GTX-2160-Y00	Single-phase	AC250/DC560	16	0.01	60	-25°C to +105°C	Screw	UL, c-UL, and TÜV	125
GTX-2160-Y02	Single-phase	AC250/DC560	16	0.50	60	-25°C to +105°C	Screw	UL, c-UL, and TÜV	126
GTX-2160-Y03	Single-phase	AC250/DC560	16	0.75	60	-25°C to +105°C	Screw	UL, c-UL, and TÜV	127
GTX-2160-Y0X	Single-phase	AC250/DC560	16	2.30	60	-25°C to +105°C	Screw	UL, c-UL, and TÜV	128
GTX-2160-Y22	Single-phase	AC250/DC560	16	1.00	60	-25°C to +105°C	Screw	UL, c-UL, and TÜV	128
GTX-2160-YXX	Single-phase	AC250/DC560	16	4.60	60	-25°C to +105°C	Screw	UL, c-UL, and TÜV	130
GTX-2200-Y00	Single-phase	AC250/DC560	20	0.01	60	-25°C to +105°C	Screw	UL, c-UL, and TÜV	128
GTX-2200-Y02	Single-phase	AC250/DC560	20	0.50	60	-25°C to +105°C	Screw	UL, c-UL, and TÜV	129
GTX-2200-Y03	Single-phase	AC250/DC560	20	0.75	60	-25°C to +105°C	Screw	UL, c-UL, and TÜV	129
GTX-2200-Y0X	Single-phase	AC250/DC560	20	2.30	60	-25°C to +105°C	Screw	UL, c-UL, and TÜV	131
GTX-2200-Y22	Single-phase	AC250/DC560	20	1.00	60	-25°C to +105°C	Screw	UL, c-UL, and TÜV	130
GTX-2200-YXX	Single-phase	AC250/DC560	20	4.60	60	-25°C to +105°C	Screw	UL, c-UL, and TÜV	133
GTX-2300-Y00	Single-phase	AC250/DC560	30	0.01	60	-25°C to +105°C	Screw	UL, c-UL, and TÜV	127
GTX-2300-Y02	Single-phase	AC250/DC560	30	0.50	60	-25°C to +105°C	Screw	UL, c-UL, and TÜV	128
GTX-2300-Y03	Single-phase	AC250/DC560	30	0.75	60	-25°C to +105°C	Screw	UL, c-UL, and TÜV	129
GTX-2300-Y0X	Single-phase	AC250/DC560	30	2.30	60	-25°C to +105°C	Screw	UL, c-UL, and TÜV	130
GTX-2300-Y22	Single-phase	AC250/DC560	30	1.00	60	-25°C to +105°C	Screw	UL, c-UL, and TÜV	130
GTX-2300-YXX	Single-phase	AC250/DC560	30	4.60	60	-25°C to +105°C	Screw	UL, c-UL, and TÜV	132
Part Number	Phase	Rated Voltage	Rated Current	Leakage Current	Temperature Rise	Operating Temperature Range	Terminal Type	Approval	Weight

<sup>1</sup> Rated DC voltage is not allowed to approval standards

<sup>2</sup> Coil surface temperature.

## Derating Curve

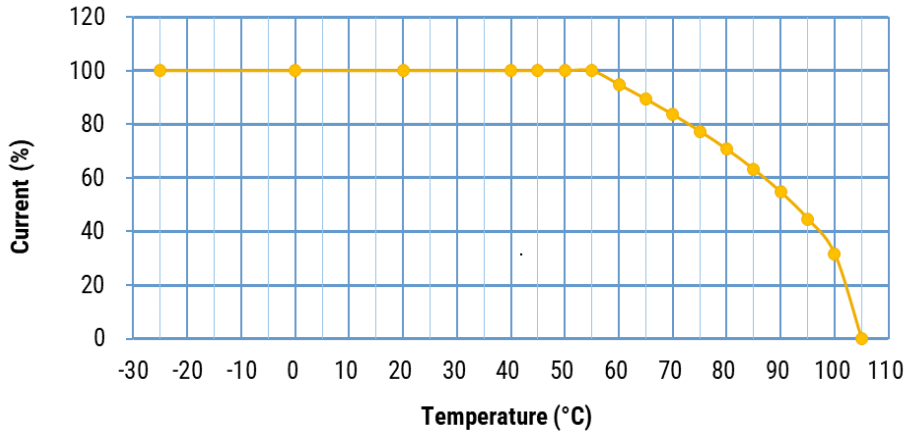

## Circuit Diagram

### Circuit Diagram

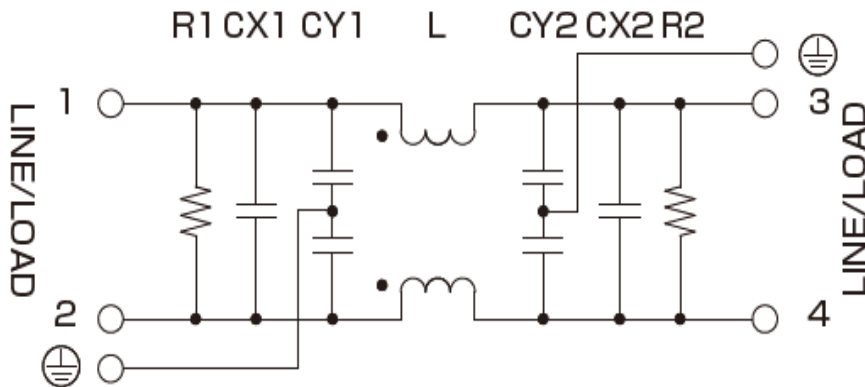

### Measuring Circuit - Common Mode

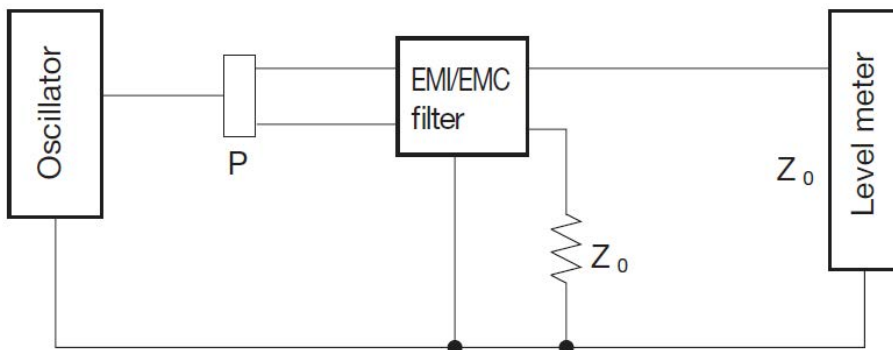

P: Power divider     $Z_0$ : 50Ω

## Attenuation (Static Characteristics)

### GTX-2060-Y\*\* Common Mode

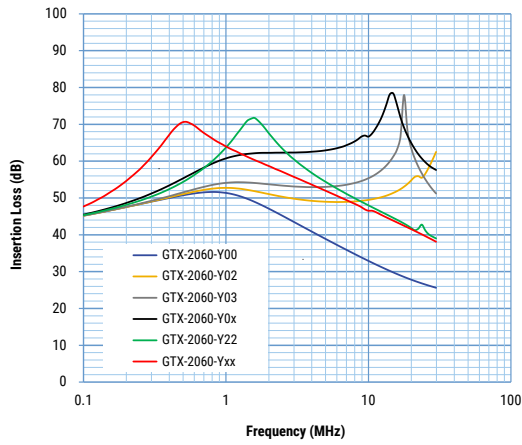

### GTX-2100-Y\*\* Common Mode

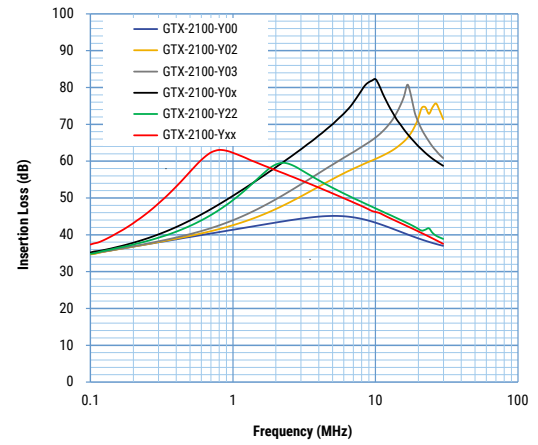

### GTX-2160-Y\*\* Common Mode

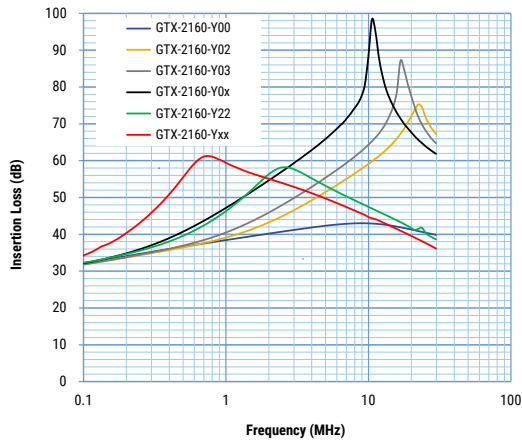

### GTX-2200-Y\*\* Common Mode

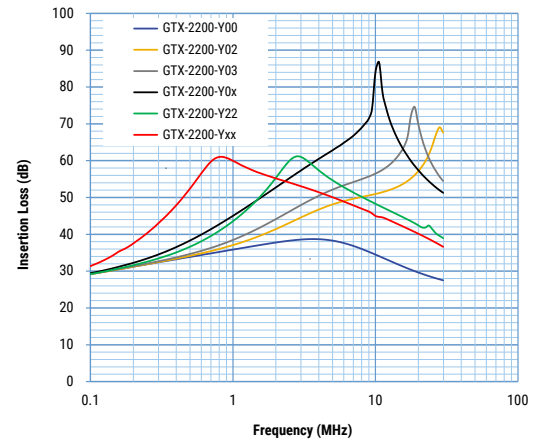

### GTX-2300-Y\*\* Common Mode

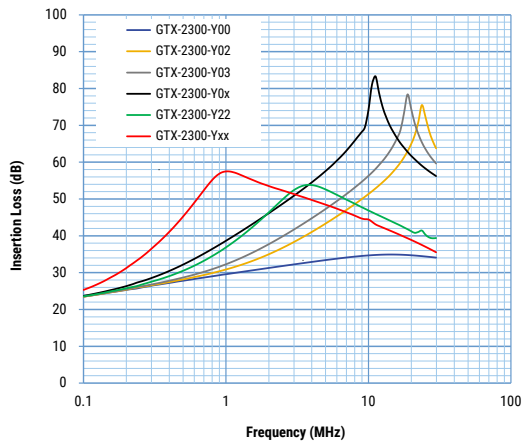

## Attenuation (Static Characteristics) cont.

**GTX-2060-Y00**

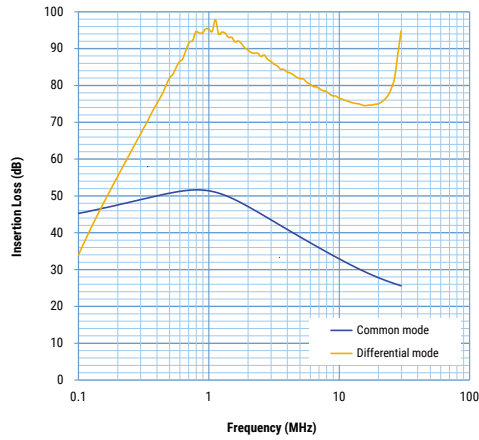

**GTX-2060-Y02**

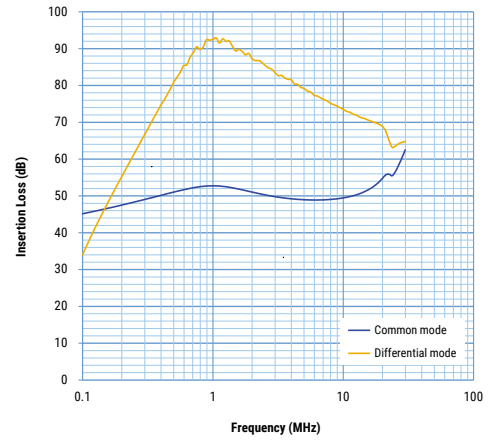

**GTX-2060-Y03**

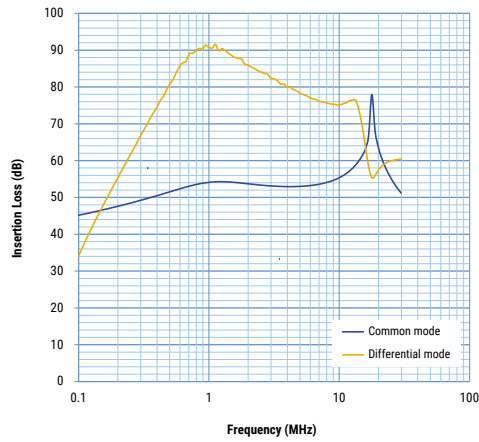

**GTX-2060-Y0X**

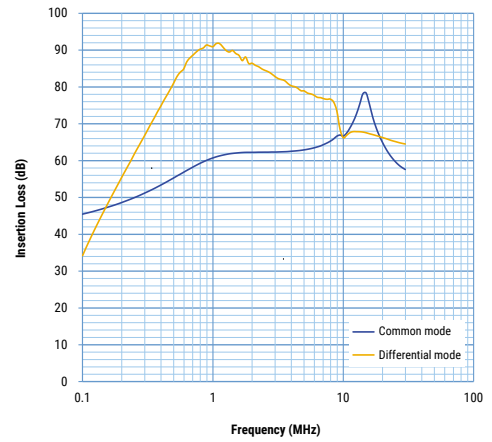

**GTX-2060-Y22**

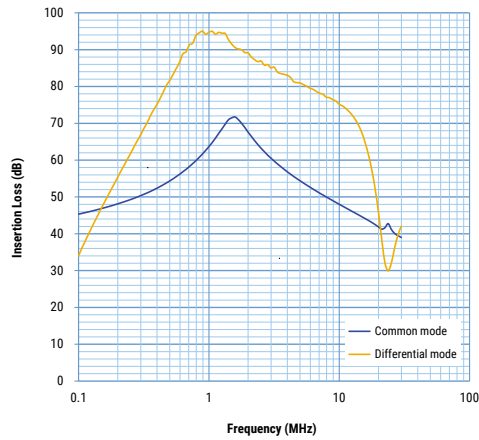

**GTX-2060-YXX**

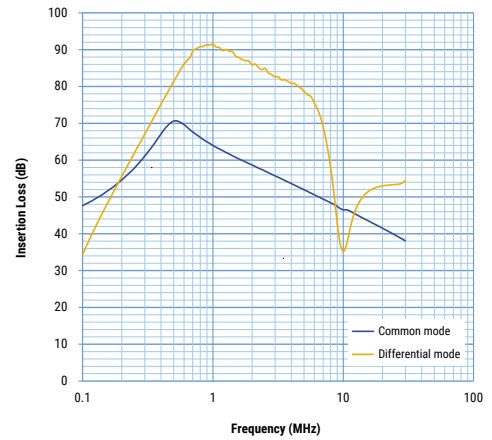

## Attenuation (Static Characteristics) cont.

**GTX-2100-Y00**

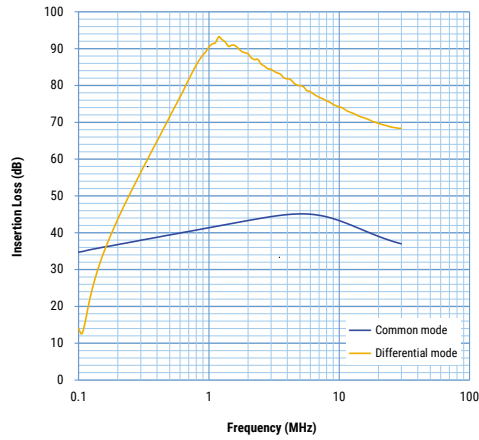

**GTX-2100-Y02**

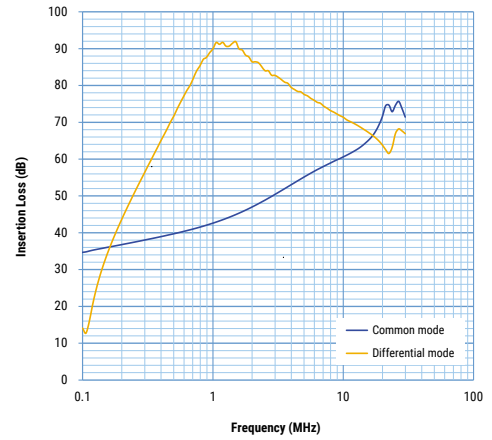

**GTX-2100-Y03**

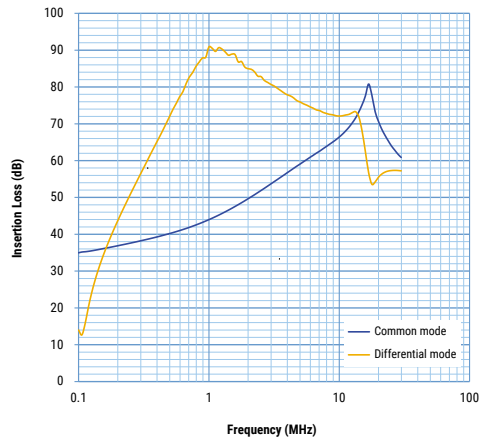

**GTX-2100-Y0X**

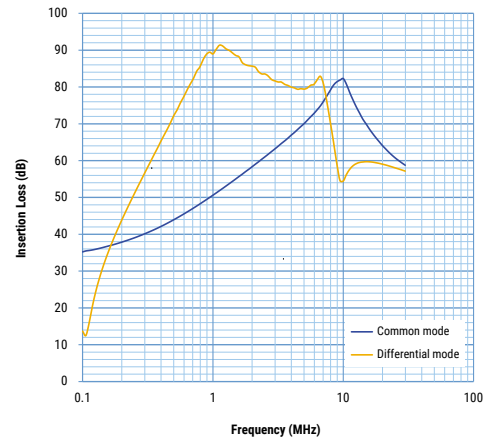

**GTX-2100-Y22**

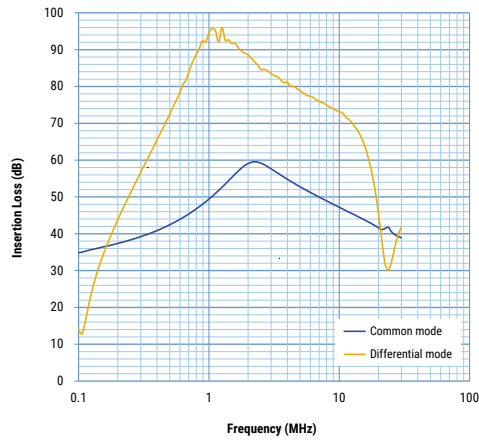

**GTX-2100-YXX**

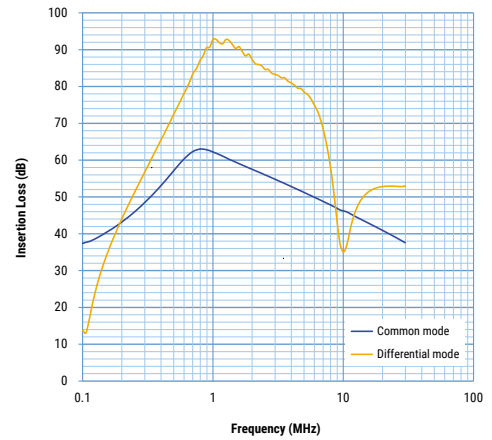



## Attenuation (Static Characteristics) cont.

**GTX-2160-Y00**

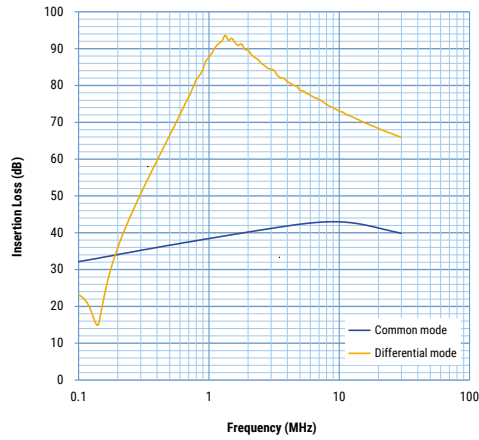

**GTX-2160-Y02**

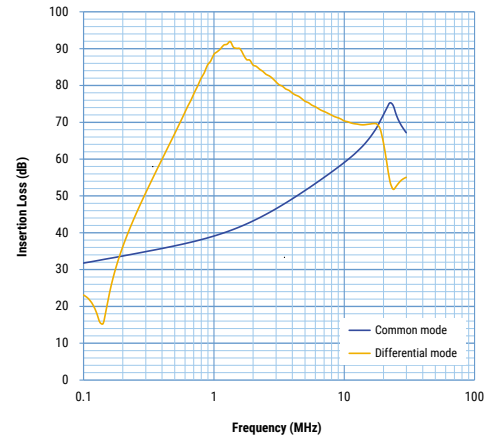

**GTX-2160-Y03**

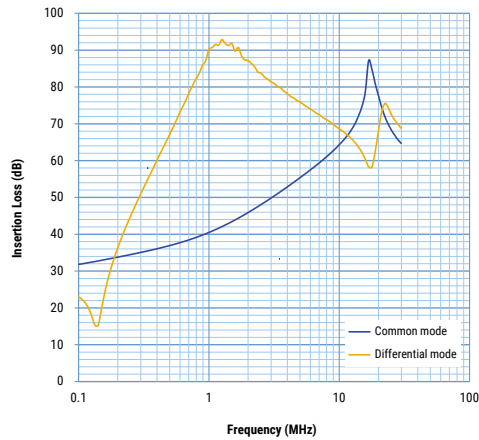

**GTX-2160-Y0X**

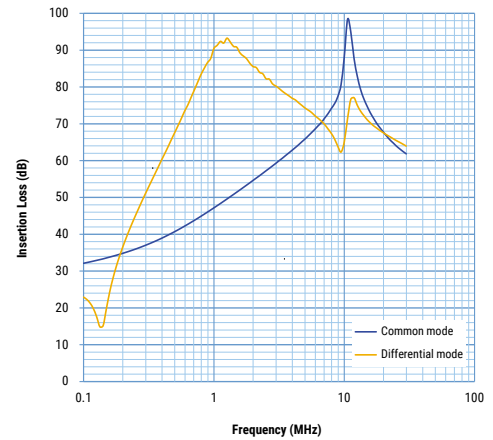

**GTX-2160-Y22**

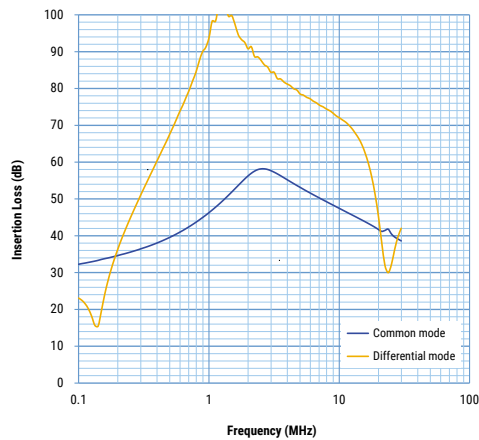

**GTX-2160-YXX**

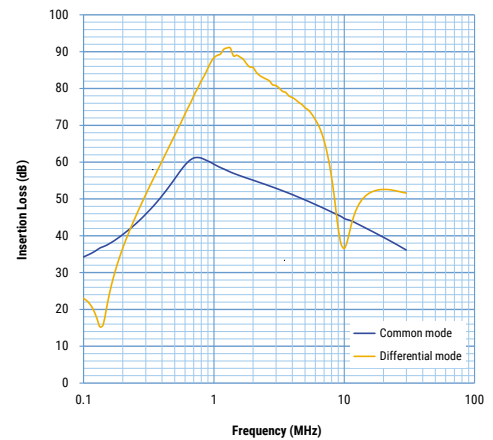

## Attenuation (Static Characteristics) cont.

**GTX-2200-Y00**

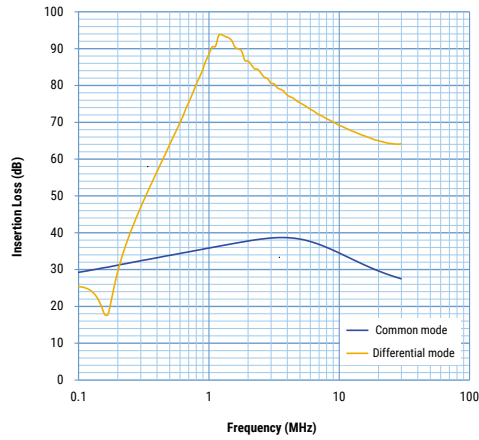

**GTX-2200-Y02**

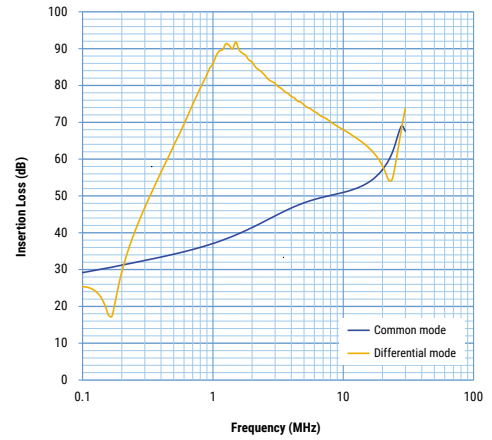

**GTX-2200-Y03**

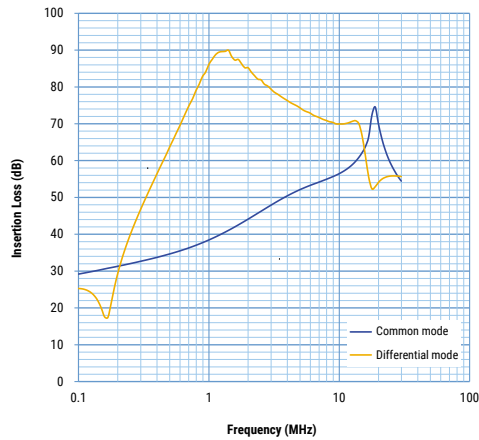

**GTX-2200-Y0X**

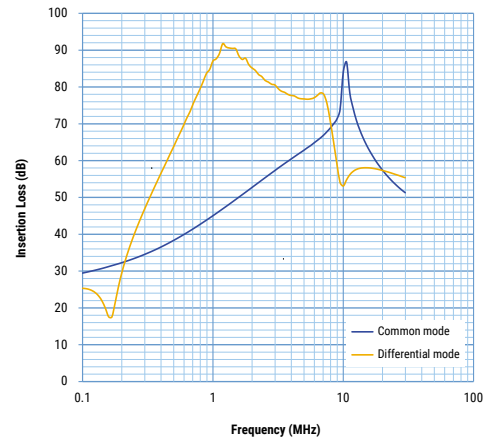

**GTX-2200-Y22**

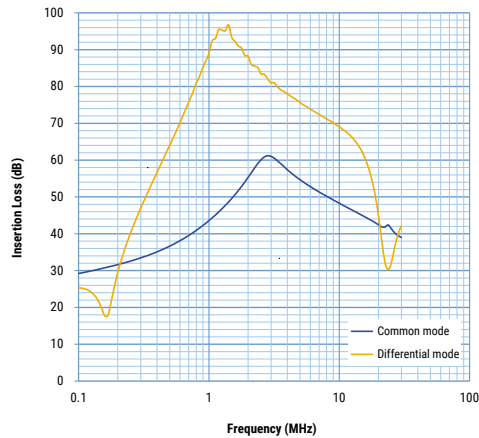

**GTX-2200-YXX**

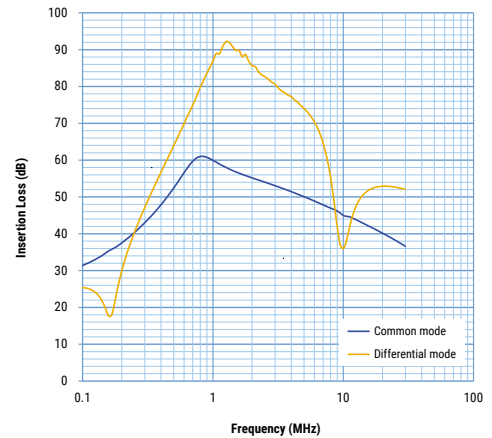

## Attenuation (Static Characteristics) cont.

**GTX-2300-Y00**

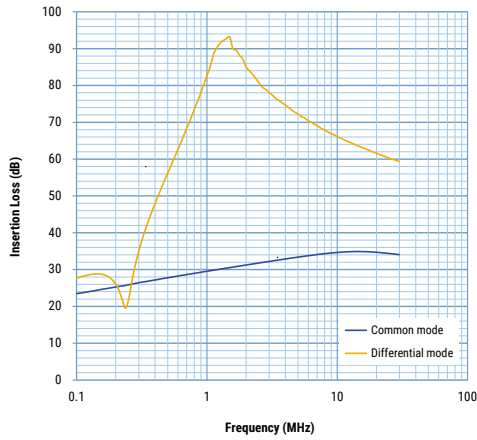

**GTX-2300-Y02**

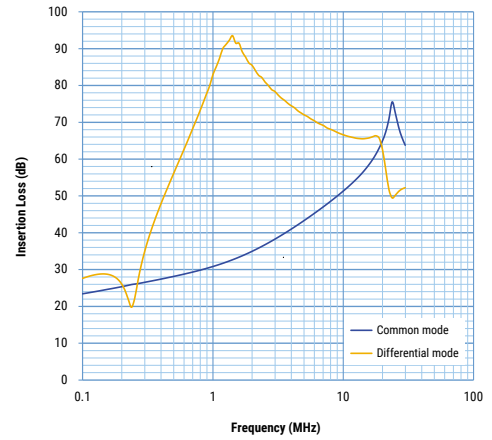

**GTX-2300-Y03**

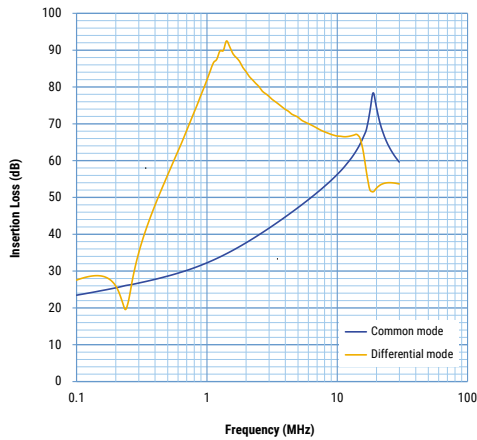

**GTX-2300-Y0X**

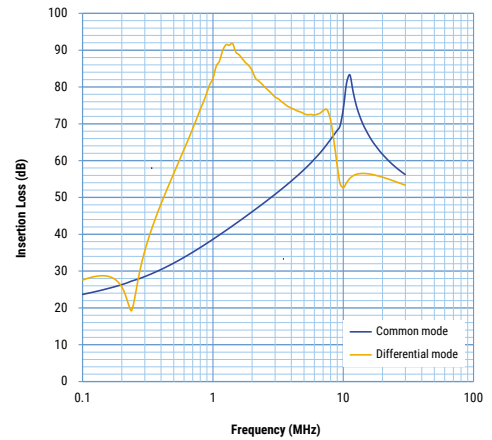

**GTX-2300-Y22**

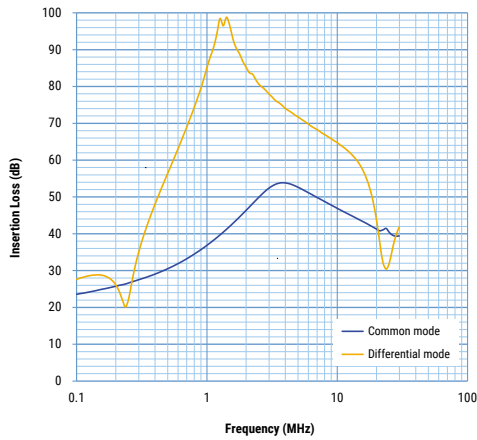

**GTX-2300-YXX**

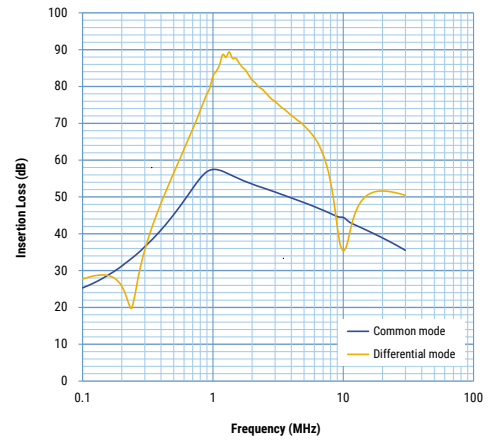

## Packaging

Part Type	Packaging Type	Pieces per Box
GTX-2**0-Y**	Box	30

## Handling Precautions

### Precautions for product storage

EMI-RFI Filters should be stored in normal working environments. While the filters themselves are quite robust in other environments, solderability will be degraded by exposure to high temperatures, high humidity, corrosive atmospheres, and long term storage.

KEMET recommends that maximum storage temperature not exceed 40°C and maximum storage humidity not exceed 70% relative humidity and atmospheres should be free of chlorine and sulfur bearing compounds. Temperature fluctuations should be minimized to avoid condensation on the parts. Also, avoid storage near strong magnetic fields as this might magnetize the product.

EMI-RFI Filters' stock should be used promptly, preferably within 12 months of receipt.

Алматы (7273)495-231  
 Ангарск (3955)60-70-56  
 Архангельск (8182)63-90-72  
 Астрахань (8512)99-46-04  
 Барнаул (3852)73-04-60  
 Белгород (4722)40-23-64  
 Брянск (4832)59-03-52  
 Владивосток (423)249-28-31  
 Владикавказ (8672)28-90-48  
 Владимир (4922)49-43-18  
 Волгоград (844)278-03-48  
 Вологда (8172)26-41-59  
 Воронеж (473)204-51-73  
 Екатеринбург (343)384-55-89

Россия +7(495)268-04-70

Иваново (4932)77-34-06  
 Ижевск (3412)26-03-58  
 Иркутск (395)279-98-46  
 Казань (843)206-01-48  
 Калининград (4012)72-03-81  
 Калуга (4842)92-23-67  
 Кемерово (3842)65-04-62  
 Киров (8332)68-02-04  
 Коломна (4966)23-41-49  
 Кострома (4942)77-07-48  
 Краснодар (861)203-40-90  
 Красноярск (391)204-63-61  
 Курск (4712)77-13-04  
 Курган (3522)50-90-47  
 Липецк (4742)52-20-81

Казахстан +7(7172)727-132

Магнитогорск (3519)55-03-13  
 Москва (495)268-04-70  
 Мурманск (8152)59-64-93  
 Набережные Челны (8552)20-53-41  
 Нижний Новгород (831)429-08-12  
 Новокузнецк (3843)20-46-81  
 Ноябрьск (3496)41-32-12  
 Новосибирск (383)227-86-73  
 Омск (3812)21-46-40  
 Орел (4862)44-53-42  
 Оренбург (3532)37-68-04  
 Пенза (8412)22-31-16  
 Петрозаводск (8142)55-98-37  
 Псков (8112)59-10-37  
 Пермь (342)205-81-47

Киргизия +996(312)96-26-47

Ростов-на-Дону (863)308-18-15  
 Рязань (4912)46-61-64  
 Самара (846)206-03-16  
 Саранск (8342)22-96-24  
 Санкт-Петербург (812)309-46-40  
 Саратов (845)249-38-78  
 Севастополь (8692)22-31-93  
 Симферополь (3652)67-13-56  
 Смоленск (4812)29-41-54  
 Сочи (862)225-72-31  
 Ставрополь (8652)20-65-13  
 Сургут (3462)77-98-35  
 Сыктывкар (8212)25-95-17  
 Тамбов (4752)50-40-97  
 Тверь (4822)63-31-35

Тольятти (8482)63-91-07  
 Томск (3822)98-41-53  
 Тула (4872)33-79-87  
 Тюмень (3452)66-21-18  
 Ульяновск (8422)24-23-59  
 Улан-Удэ (3012)59-97-51  
 Уфа (347)229-48-12  
 Хабаровск (4212)92-98-04  
 Чебоксары (8352)28-53-07  
 Челябинск (351)202-03-61  
 Череповец (8202)49-02-64  
 Чита (3022)38-34-83  
 Якутск (4112)23-90-97  
 Ярославль (4852)69-52-93