

Overview

KEMET's QFS pyroelectric flame sensors combine high sensitivity with fast response times and high dynamic range to ensure rapid and accurate detection of small and large flames, nearby or over larger distances.

These high quality sensors, in their small SMD package, integrate a digital, current mode read-out offering high responsivity over the full frequency range of flame flicker from 3 – 30 Hz. Industry standard I²C communication enables plug-and-play connectivity to microcontrollers and allows easy tuning and calibration. Programmable gain and filtering offer maximum flexibility in system design, and various optical filter options are also available. These sensors can be connected together in a linear series for synchronized sampling across devices.

Their long and maintenance-free operational lifetime and various low power modes make these sensors ideal for any smart or IoT type of applications.

Benefits

- High sensitivity with fast response time
- High dynamic range
- Small SMD package
- Digital output and I²C communication
- Programmable gain and filtering
- Various optical filter options
- Integrated configurable amplifier, filter and ADC
- Low power consumption
- Sensor modules and digital evaluation kit available for easy evaluation and quick prototype development (ref QFSM Series)

Applications

- Smart home
- Smart building
- Industrial IoT
- Transportation

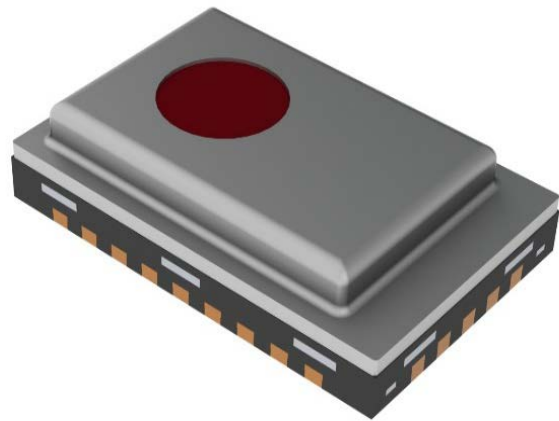

Алматы (7273)495-231
Ангарск (3955)60-70-56
Архангельск (8182)63-90-72
Астрахань (8512)99-46-04
Барнаул (3852)73-04-60
Белгород (4722)40-23-64
Благовещенск (4162)22-76-07
Брянск (4832)59-03-52
Владивосток (423)249-28-31
Владикавказ (8672)28-90-48
Владимир (4922)49-43-18
Волгоград (844)278-03-48
Вологда (8172)26-41-59
Воронеж (473)204-51-73
Екатеринбург (343)384-55-89

Россия +7(495)268-04-70

Иваново (4932)77-34-06
Ижевск (3412)26-03-58
Иркутск (395)279-98-46
Казань (843)206-01-48
Калининград (4012)72-03-81
Калуга (4842)92-23-67
Кемерово (3842)65-04-62
Киров (8332)68-02-04
Коломна (4966)23-41-49
Кострома (4942)77-07-48
Краснодар (861)203-40-90
Красноярск (391)204-63-61
Курск (4712)77-13-04
Курган (3522)50-90-47
Липецк (4742)52-20-81

Казахстан +7(7172)727-132

Магнитогорск (3519)55-03-13
Москва (495)268-04-70
Мурманск (8152)59-64-93
Набережные Челны (8552)20-53-41
Нижний Новгород (831)429-08-12
Новокузнецк (3843)20-46-81
Новый Уренгой (3496)41-32-12
Новосибирск (383)227-86-73
Омск (3812)21-46-40
Орел (4862)44-53-42
Оренбург (3532)37-68-04
Пенза (8412)22-31-16
Петрозаводск (8142)55-98-37
Псков (8112)59-10-37
Пермь (342)205-81-47

Киргизия +996(312)96-26-47

Ростов-на-Дону (863)308-18-15
Рязань (4912)46-61-64
Самара (846)206-03-16
Саранск (8342)22-96-24
Санкт-Петербург (812)309-46-40
Саратов (845)249-38-78
Севастополь (8692)22-31-93
Симферополь (3652)67-13-56
Смоленск (4812)29-41-54
Сочи (862)225-72-31
Ставрополь (8652)20-65-13
Сургут (3462)77-98-35
Сыктывкар (8212)25-95-17
Тамбов (4752)50-40-97
Тверь (4822)63-31-35

Тольятти (8482)63-91-07
Томск (3822)98-41-53
Тула (4872)33-79-87
Тюмень (3452)66-21-18
Ульяновск (8422)24-23-59
Улан-Удэ (3012)59-97-51
Уфа (347)229-48-12
Хабаровск (4212)92-98-04
Чебоксары (8352)28-53-07
Челябинск (351)202-03-61
Череповец (8202)49-02-64
Чита (3022)38-34-83
Якутск (4112)23-90-97
Ярославль (4852)69-52-93

Ordering Information

USE	QFS	E	A	22L1	8	0
Product Family	Series	Sensor Type	Mounting Type	Specification	Packaging	Version
Sensors	QFS = SMD IR Flame Sensors	E = Serial output	A = Sensor only	0000 = Fixed 22L1 = 2.2 μm long pass (broadband flame detection) 50L1 = 5.00 μm long pass (human motion rejection) 3911 = 3.91 μm (rejection channel) 4641 = 4.64 μm (flame channel with wide FoV) 4481 = 4.48 μm (flame channel with main detector)	8 = 7" Tape & Reel	0

Environmental Compliance

All KEMET Flame Sensors are RoHS and REACH Compliant.



Article 33(1) of the REACH Regulation states that manufacturers and importers of articles (products) are required to notify their customers of the presence of any Substances of Very High Concern (SVHC) in their products exceeding 0.1% by weight and provide instructions on safe use of the product.

KEMET Corporation reports regarding the Article 33(1) of REACH Regulation as follows:

1. *Applicable Product: Flame Sensors (QFC, QFCE, QFS & QFSM series)*

2. *Report for the content of REACH SVHC list:*

The product(s) above contains a substance by more than 0.1wt% per product weight that was published in the 8th update of the REACH SVHC substances (December 19, 2012).

3. *Regarding the safety of the flame sensors (Piezoceramic products):*

The Piezoceramic that is used in this product becomes ceramic by sintering powder containing PZT as the main ingredient. It is chemically stable, with minimum risks toward the human body or environment within the intended use of the product. Please note that risks could occur in the case of inhalation or accidental oral uptake of powder ceramics.

4. *Technical product information on the flame sensors (Piezoceramic products):*

The manufacturing technique of the "piezoceramic products" whose main ingredient is Lead Titanium Zirconium Oxide (PZT) has been established, and there is no alternative material that can exhibit superior performance than PZT at this moment. Please note that the piezoceramic is listed as an exempt on RoHS (2011/65/EU) AnnexIII (7c.1).

5. *The responsibility of piezoceramic manufacturers:*

Piezoceramic manufacturers report information regarding PZT containment in their products to the customers to obey the article 33 of the REACH regulation

Dimensions – Millimeters

Sensor

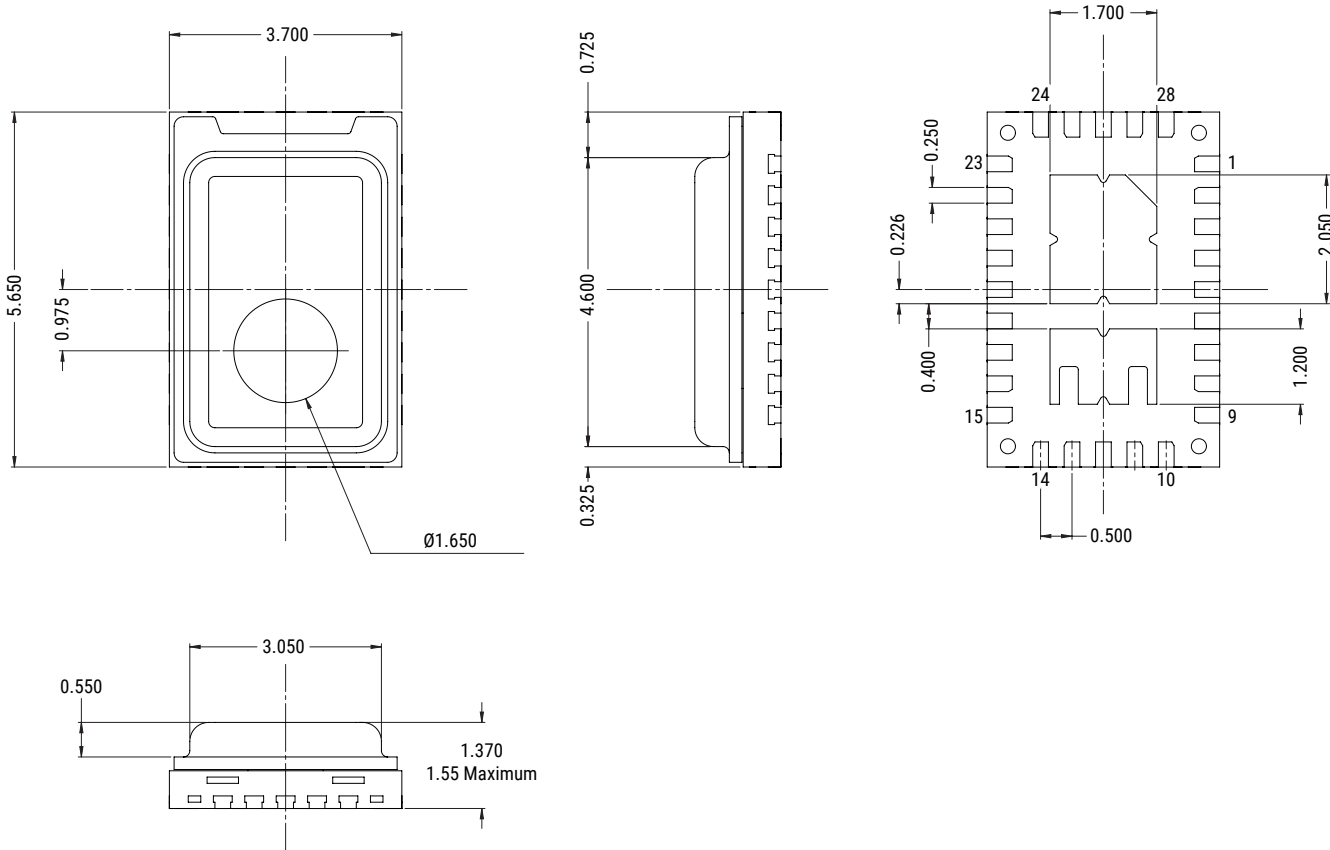

Pin Configuration of Sensor

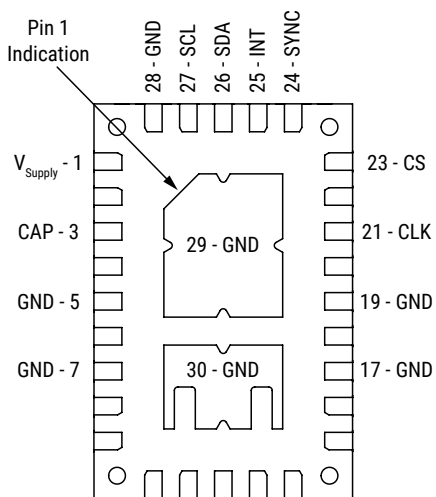

Transparent Top View

Recommended Circuit Diagram

Single Device Block Diagram

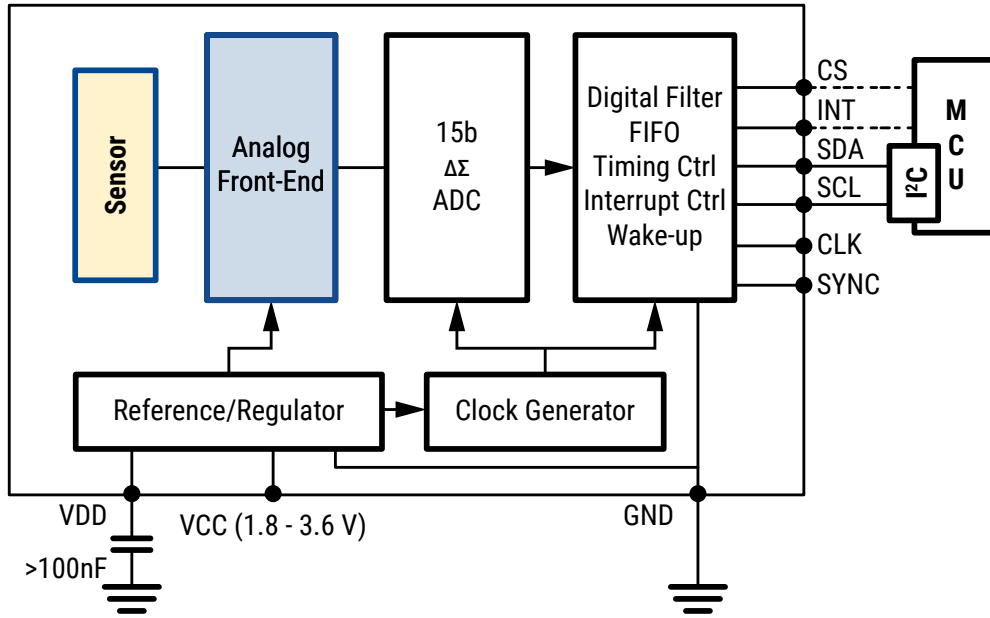

Three Devices with Synchronised Sampling

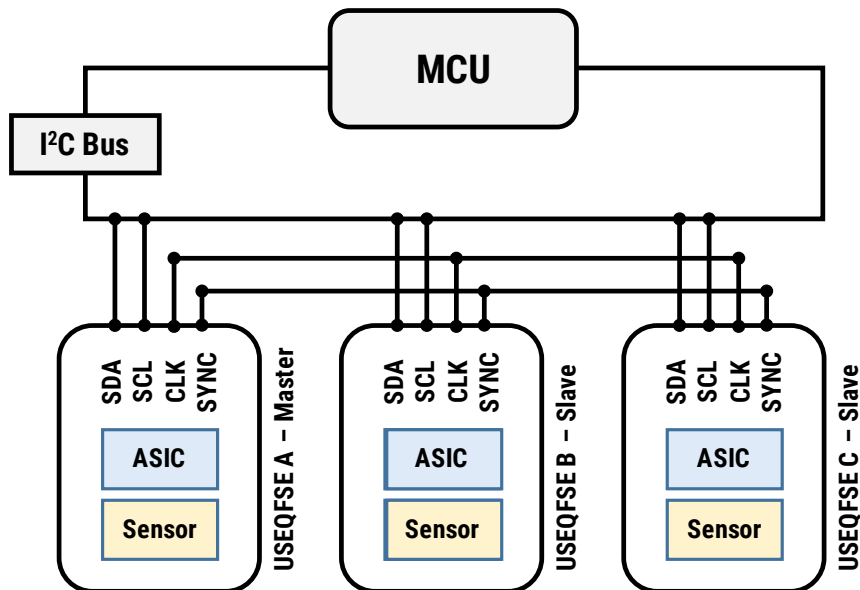

Performance Characteristics

Signal Filtering & Power Modes

Power Mode (base sample rate)	High Pass Filter – Analog (Hz)					Fixed Analog Low Pass Filter (Hz)	Fixed Digital Low Pass Filter (Hz)	Digital Low Pass Filter (Hz)				Maximum ADC Sampling Rate (sps)
	Off	1.0	2.0	4.0	8.0			180.0	90.0	45.0	22.5	
Normal Power Mode	Off	1.0	2.0	4.0	8.0	600	250	180.0	90.0	45.0	22.5	1,000
Low Power Mode	Off	0.17	0.33	0.66	1.30	100	42	30.00	15.00	7.50	3.75	166

Item	Mode	Description	Typical Current Consumption (1.8 V, room temperature)
Power consumption	Normal Power Mode	Normal power consumption, 1 kHz maximum sample rate	22 μ A
	Low Power Mode	Low power consumption, 166 Hz maximum sample rate	3.5 μ A
Operational state	Normal Operation Mode	Sensor signal readout over I ² C	22 μ A
	Sleep Mode	Hardware interrupt on infrared trigger	21 μ A (Normal Power Mode) 3.5 μ A (Low Power Mode)
	Power Down Mode	Sensor is disabled	1.1 μ A

Infrared Frequency Characteristics

Typical Frequency Response in Normal Power Mode

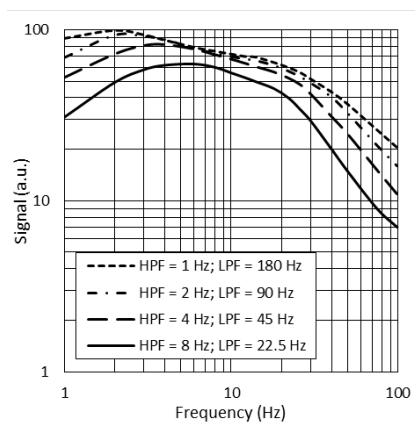

Typical Frequency Response in Low Power Mode

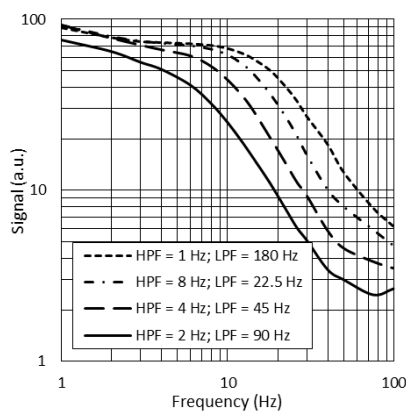

Typical Frequency Response at Different Gain Settings

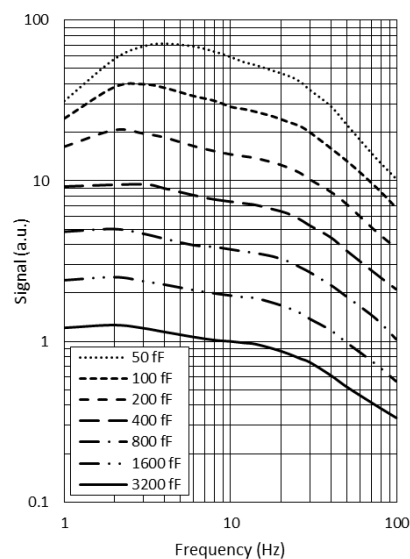

Performance Characteristics cont.

Filter Transmission Profiles

Typical 2.2 μm LP Filter Transmission

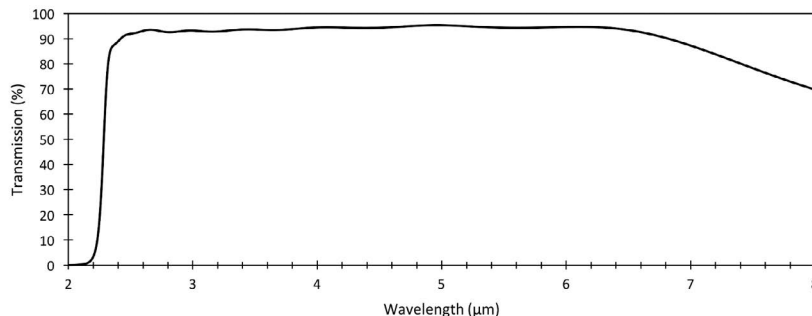

Typical 5.0 μm LP Filter Transmission

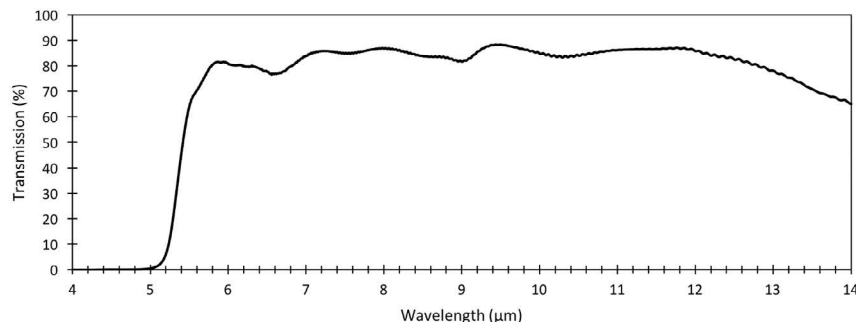

Part Number Specifications

Sensor Characteristics

Filter Aperture (mm)	Element Size (mm ²)	SMD Package (mm)	D* ¹ (cm√Hz/W) Typical	NEP ¹ (W/√Hz) Typical	Time Constant (ms) at 10-20 Hz peak	Field of View
φ 1.65	0.64 x 0.64	5.65 x 3.70 x 1.55	2.5 x 10 ⁸	2.7 x 10 ⁻¹⁰	~10	~90°

¹ 10 Hz, 500 K, room temperature, without window and optics.

Electrical Characteristics

Supply Voltage (V)	Supply Current (μA) Typical	Digital I/O	ΔΣ ADC at 1 ksp	Operating Temperature Range (°C)	Storage Temperature Range (°C)	Sensor Read-out	Configurable
1.75 to 3.60	1 to 23	I ² C (FM+ compatible)	15 bit	-40 to +85	-40 to +110	Current mode	Gain Digital filtering Sampling rate Power modes

Part Number Specifications cont.

Part Number (Sensor)

Part Number	Filter(μm)	Filter BW (nm)	Comment	Weight (gr)
USEQFSEA22L180	2.20	Long pass	Broadband flame detection	0.07
USEQFSEA50L180	5.00	Long pass	Human motion rejection	0.07
USEQFSEA391180	3.91	90	Rejection channel	0.07
USEQFSEA464180	4.64	180	Flame channel (wide FoV)	0.07
USEQFSEA448180	4.48	620	Flame channel (main detector)	0.07

Landing Pattern

Recommended PCB Landing Pattern - Millimeters

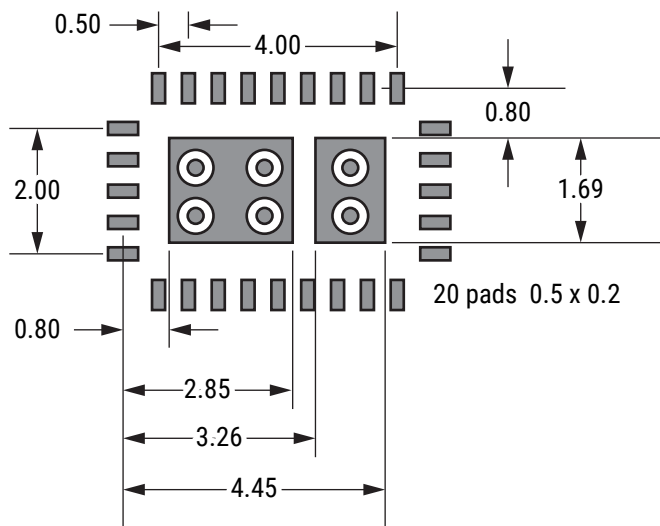

Soldering Process

Recommended Reflow Soldering Profile

Profile Feature	Pb-Free Assembly
Preheat/Soak	
Temperature Minimum (T_{smin})	150°C
Temperature Maximum (T_{smax})	200°C
Time (t_s) from T_{smin} to T_{smax}	60 – 120 seconds
Ramp-Up Rate (T_L to T_p)	3°C/second maximum
Liquidous Temperature (T_L)	217°C
Time Above Liquidous (t_L)	60 – 150 seconds
Peak Temperature (T_p)	260°C
Time within 5°C of Maximum Peak Temperature (t_p) ¹	30 seconds maximum
Ramp-Down Rate (T_p to T_L)	6°C/second maximum
Time 25°C to Peak Temperature	8 minutes maximum

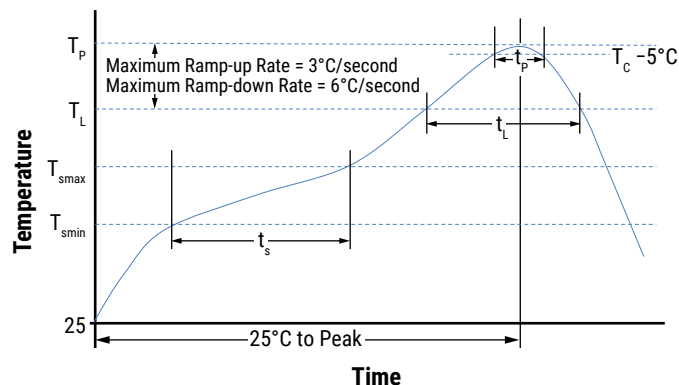

¹ Tolerance for peak profile temperature (TP) is defined as a supplier minimum and as a user maximum.

Packaging

Series	Packaging Type	Pieces per Reel
QFS	7" Tape & Reel	800

Taping Specification

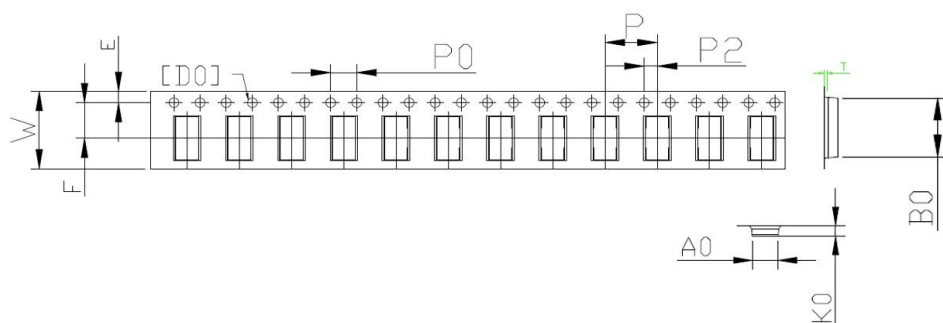

	Dimensions (mm)										
	P0	P	T	P2	W	A0	B0	K0	E	F	D0
Minimum	3.90	7.90	0.25	1.90	11.70	3.90	5.85	1.65	1.65	5.40	1.50
Typical	4.00	8.00	0.30	2.00	12.00	4.00	5.95	1.75	1.75	5.50	1.50
Maximum	4.10	8.10	0.35	2.10	12.30	4.10	6.05	1.85	1.85	5.60	1.60

Reel Specification

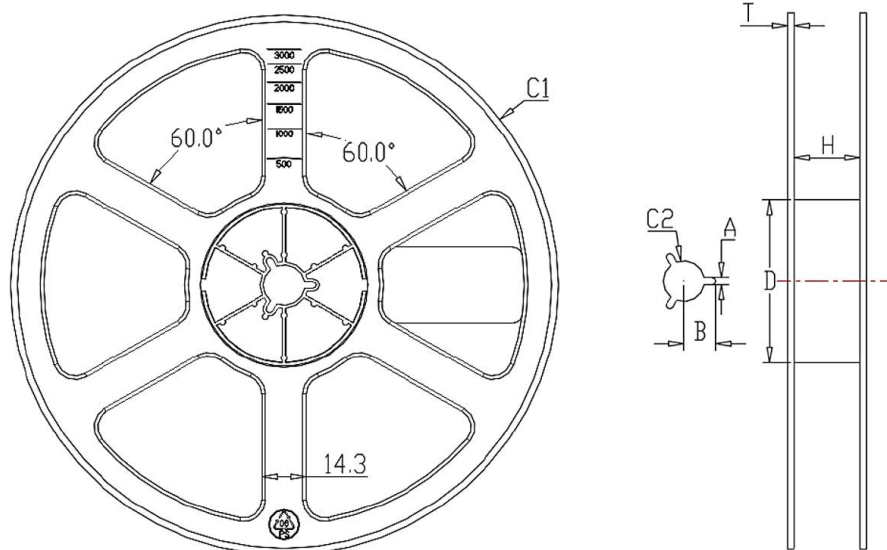

	Dimensions (mm)						
	C1	C2	A	B	H	T	D
Tolerance	±1.0	±0.2	±0.2	±0.2	±0.5	±0.2	±0.5
Nominal	Ø178	13.5	2.3	10.4	12.5	1.6	Ø54

Handling Precautions

Pyroelectric Infrared Sensors should be kept away from indirect and direct sunlight, the headlights of cars, wind, and exposure to strong vibration and strong shock.

Do not use in water, alcohol ETA, corrosive gas or under sea breeze.

Do not be expose to corrosive substances.

Do not drop or apply any mechanical stress.

The performance of this device can be affected by ESD. Precautions should be used when handling and installing the sensor. Precision devices such as this sensor can be damaged or caused not to meet published specification due to ESD. Please note that there is limited ESD protection built-in as the device is optimised for low power consumption and low noise operation. Human Body Model (HBM), per JS-001: 2,000 V.

The sensor is classed as Moisture Sensitivity Level 3 (MSL-3). The package should be handled according to IPC/JEDEC J-STD-20.

Pyroelectric Infrared Sensors should be stored in normal working environments.

Solderability will be degraded by exposure to high temperatures, high humidity, corrosive atmospheres, and long-term storage.

KEMET recommends that ambient storage conditions are < 30°C and < 60% relative humidity and that maximum storage temperature does not exceed 110°C. Atmospheres should be free of chlorine and sulfur-bearing compounds.

Temperature fluctuations should be minimized to avoid condensation on the parts.

For optimized solderability sensors stock should be used promptly, preferably within 24 months of receipt.

QFSM Pyroelectric Infrared Flame Sensor Modules, I²C-SMD

Overview

KEMET's QFSM pyroelectric flame sensor modules combine high sensitivity with fast response times and high dynamic range to ensure rapid and accurate detection of small and large flames, nearby or over larger distances. The flame sensor modules consist of a breakout board, on which a SMD flame sensor is mounted, ideal for easy evaluation and quick prototype development. These sensors integrate a digital, current mode read-out offering high responsivity over the full frequency range of flame flicker from 3 - 30 Hz. Industry standard I²C communication enables plug-and-play connectivity to microcontrollers and allows easy tuning and calibration. Programmable gain and filtering offer maximum flexibility in system design, and various optical filter options are also available. These sensors can be connected together in linear series to allow synchronized sampling across devices.

For further in-depth testing of these flame sensing solutions, KEMET is proposing also an evaluation kit to enable engineers and technicians to carry out simple and effective evaluation of KEMET SMD flame sensors, experiment with the sample flame detection ratio based algorithm, and to capture measured data to a PC.

Applications

- Smart home
- Smart building
- Industrial IoT
- Transportation

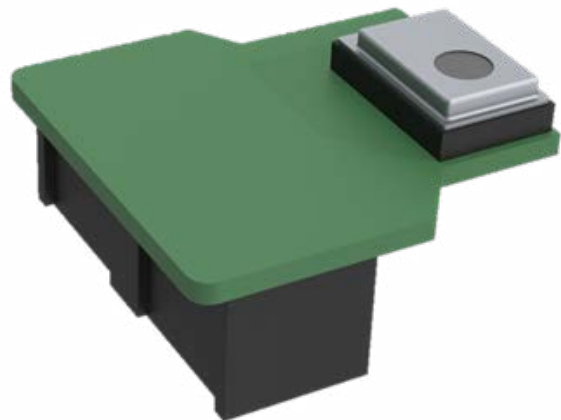

Benefits

- High sensitivity with fast response time and high dynamic range
- Digital output and I²C communication
- Programmable gain and filtering
- Various optical filter options
- Integrated configurable amplifier, filter and ADC
- Low power consumption
- Sensor modules for easy evaluation and quick prototype development
- Evaluation kit for digital SMD flame sensing
- Easy to install and user-friendly software

Ordering Information

USE	QFS	E	A	C821	8	0
Product Family	Series	Sensor Type	Mounting Type	Specification	Packaging	Version
Sensors	QFS = SMD IR Flame Sensors	M = Serial module K = Evaluation kit	1 = Module type 1 or kit type 1	0000 = Fixed 22L1 = 2.2 μm long pass (broadband flame detection) 50L1 = 5.00 μm long pass (human motion rejection) 3911 = 3.91 μm (rejection channel) 4641 = 4.64 μm (flame channel with wide FoV) 4481 = 4.48 μm (flame channel with main detector)	0 = Bulk	0

Environmental Compliance

All KEMET Flame Sensors are RoHS and REACH Compliant.



Article 33(1) of the REACH Regulation states that manufacturers and importers of articles (products) are required to notify their customers of the presence of any Substances of Very High Concern (SVHC) in their products exceeding 0.1% by weight and provide instructions on safe use of the product.

KEMET Corporation reports regarding the Article 33(1) of REACH Regulation as follows:

1. *Applicable Product: Flame Sensors (QFC, QFCE, QFS & QFSM series)*

2. *Report for the content of REACH SVHC list:*

The product(s) above contains a substance by more than 0.1wt% per product weight that was published in the 8th update of the REACH SVHC substances (December 19, 2012).

3. *Regarding the safety of the flame sensors (Piezoceramic products):*

The Piezoceramic that is used in this product becomes ceramic by sintering powder containing PZT as the main ingredient. It is chemically stable, with minimum risks toward the human body or environment within the intended use of the product. Please note that risks could occur in the case of inhalation or accidental oral uptake of powder ceramics.

4. *Technical product information on the flame sensors (Piezoceramic products):*

The manufacturing technique of the "piezoceramic products" whose main ingredient is Lead Titanium Zirconium Oxide (PZT) has been established, and there is no alternative material that can exhibit superior performance than PZT at this moment. Please note that the piezoceramic is listed as an exempt on RoHS (2011/65/EU) AnnexIII (7c.1).

5. *The responsibility of piezoceramic manufacturers:*

Piezoceramic manufacturers report information regarding PZT containment in their products to the customers to obey the article 33 of the REACH regulation

Dimensions – Millimeters

Module

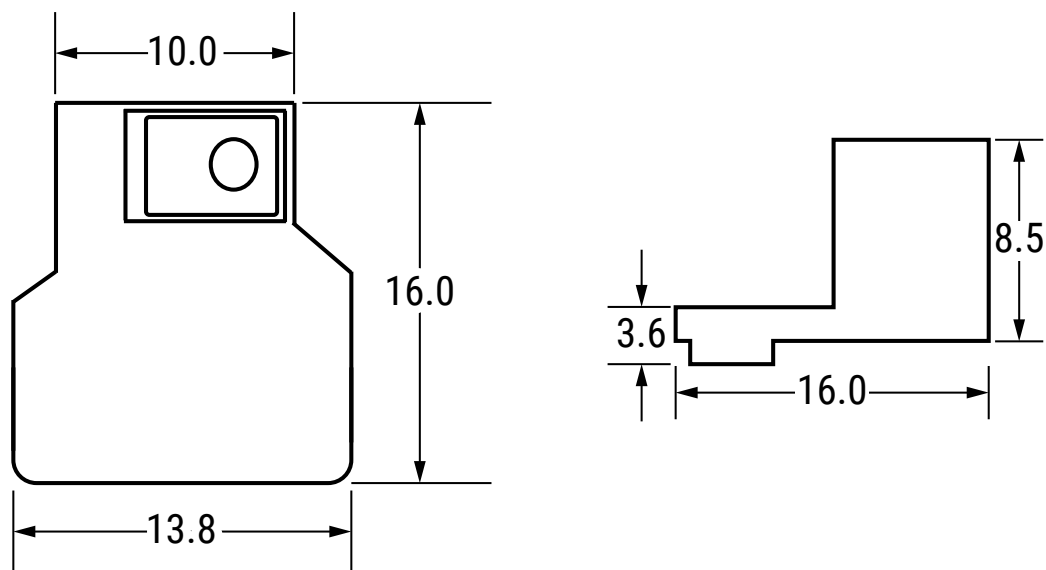

Cable

Female Connector

Female Connector

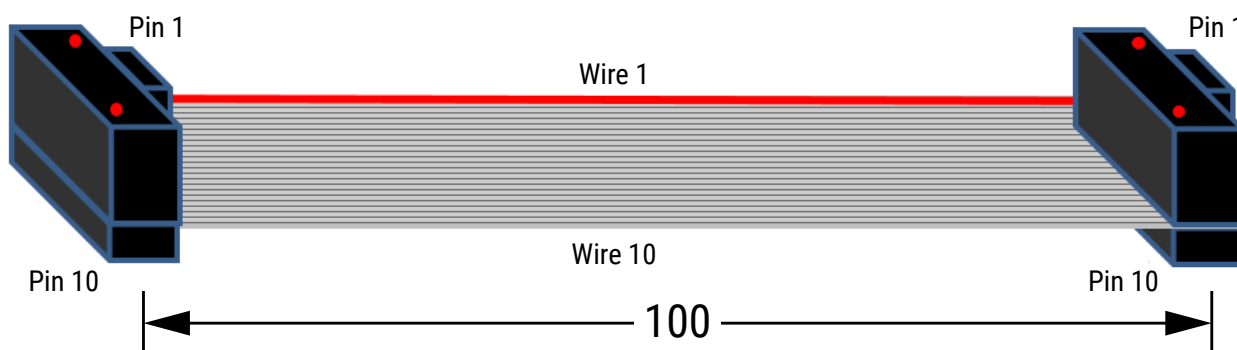

Dimensions – Millimeters cont.

Pin Configuration of the Module

Outfitted with all necessary components for the 1.8-3.6 V power supply of the device, all functionality of the sensor is routed out to a 10-pin 1.27 mm pitch IDC connector on the back side of the 16 x 13.8 mm PCB. The build height including the socket is 9 mm. They provide up to 1 MHz Fast Mode+ I²C communication to configure the sensor and read data from it.

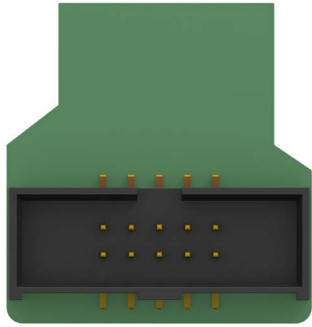

•9	•7	•5	•3	•1
•10	•8	•6	•4	•2

Pin	Symbol	Type
1	V _{supply}	Power supply
2	Unassigned	-
3	SCL (I ² C)	Digital in/out
4	SDA (I ² C)	Digital in/out
5	CS	Digital in
6	INT	Digital out
7	SYNC	Digital in/out
8	CLK	Digital in/out
9	Unassigned	-
10	GND	Ground

There is a chip select/enable pin and an interrupt output available. The CLK/SYNC pins can be used to feed an external clock signal in to the board or, alternatively, distribute the clock signal of one board to several other boards, thereby creating a synchronized “network” of sensors.

Field of View

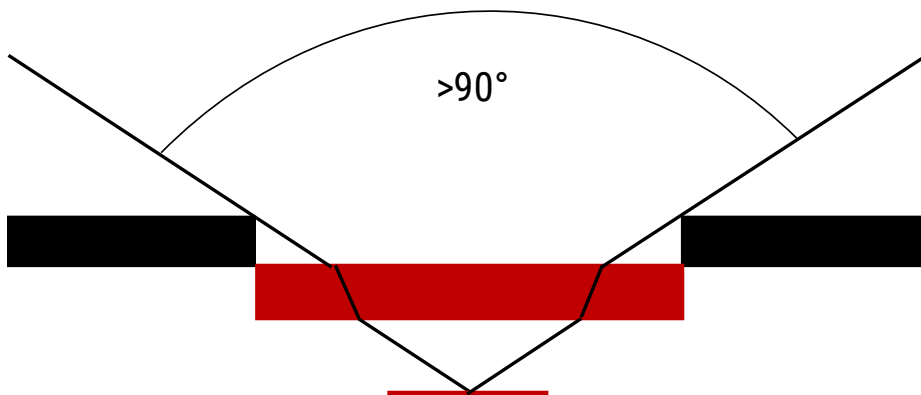

Performance Characteristics

Signal Filtering & Power Modes

Power Mode (base sample rate)	High Pass Filter – Analog (Hz)					Fixed Analog Low Pass Filter (Hz)	Fixed Digital Low Pass Filter (Hz)	Digital Low Pass Filter (Hz)				Maximum ADC Sampling Rate (sps)
	Off	1.0	2.0	4.0	8.0			180.0	90.0	45.0	22.5	
Normal Power Mode	Off	1.0	2.0	4.0	8.0	600	250	180.0	90.0	45.0	22.5	1,000
Low Power Mode	Off	0.17	0.33	0.66	1.30	100	42	30.00	15.00	7.50	3.75	166

Item	Mode	Description	Typical Current Consumption (1.8 V, room temperature)
Power consumption	Normal Power Mode	Normal power consumption, 1 kHz maximum sample rate	22 μ A
	Low Power Mode	Low power consumption, 166 Hz maximum sample rate	3.5 μ A
Operational state	Normal Operation Mode	Sensor signal readout over I ² C	22 μ A
	Sleep Mode	Hardware interrupt on infrared trigger	21 μ A (Normal Power Mode) 3.5 μ A (Low Power Mode)
	Power Down Mode	Sensor is disabled	1.1 μ A

Infrared Frequency Characteristics

Typical Frequency Response in Normal Power Mode

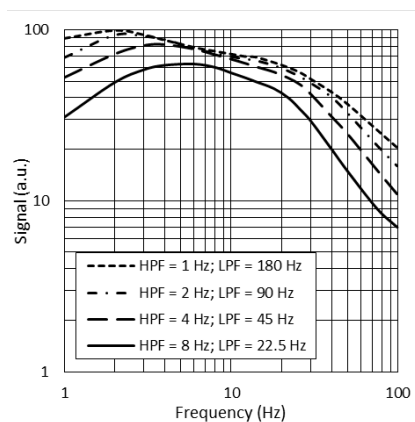

Typical Frequency Response in Low Power Mode

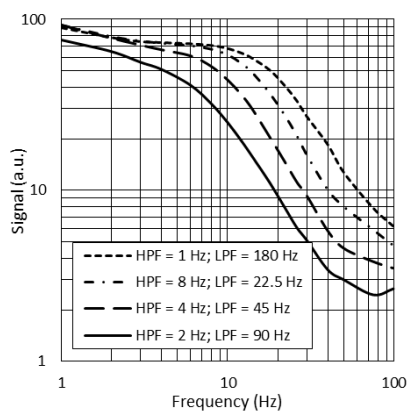

Typical Frequency Response at Different Gain Settings

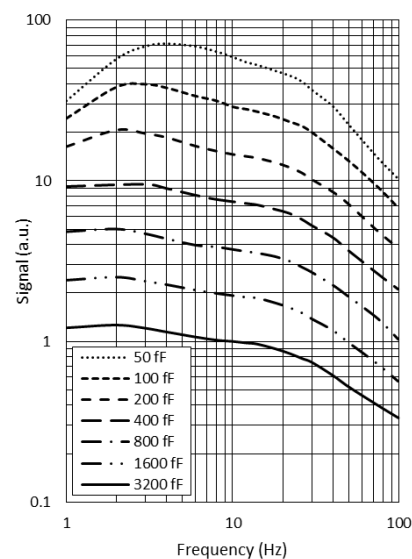

Performance Characteristics cont.

Filter Transmission Profiles

Typical 2.2 μm LP Filter Transmission

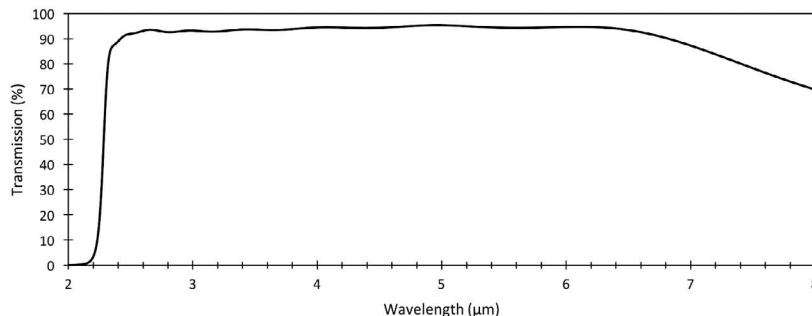

Typical 5.0 μm LP Filter Transmission

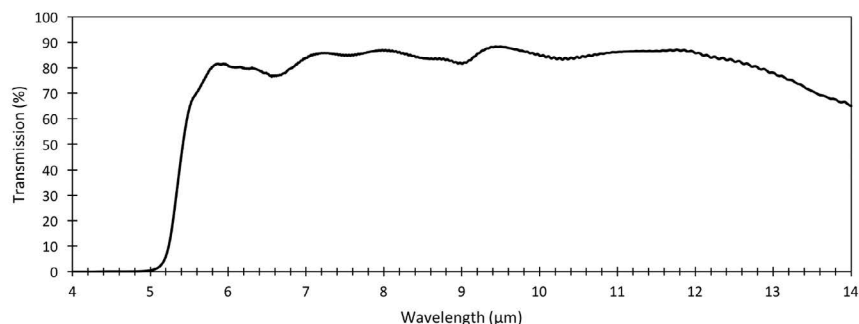

Part Number Specifications

Sensor Characteristics

Filter Aperture (mm)	Element Size (mm ²)	SMD Package (mm)	D* ¹ (cm√Hz/W) Typical	NEP ¹ (W/√Hz) Typical	Time Constant (ms) at 10-20 Hz peak	Field of View
φ 1.65	0.64 x 0.64	5.65 x 3.70 x 1.55	2.5 x 10 ⁸	2.7 x 10 ⁻¹⁰	~10	~90°

¹ 10 Hz, 500 K, room temperature, without window and optics.

Electrical Characteristics

Supply Voltage (V)	Supply Current (μA) Typical	Digital I/O	ΔΣ ADC at 1 ksp	Operating Temperature Range (°C)	Storage Temperature Range (°C)	Sensor Read-out	Configurable
1.75 to 3.60	1 to 23	I ² C (FM+ compatible)	15 bit	-40 to +85	-40 to +110	Current mode	Gain Digital filtering Sampling rate Power modes

Part Number Specifications cont.

Part Number (Module)

Part Number	Comment	Weight (gr)
USEQFSM122L100	Includes sensor: USEQFSEA22L180	5.40
USEQFSM150L100	Includes sensor: USEQFSEA50L180	5.40
USEQFSM1391100	Includes sensor: USEQFSEA391180	5.40
USEQFSM1464100	Includes sensor: USEQFSEA464180	5.40
USEQFSM1448100	Includes sensor: USEQFSEA448180	5.40

Evaluation Kits

Control Board for Module

Part Number	Use	Includes	Weight
USEQCSK0000000	Control Board for Modules	Preassembled backplane PCB USB communications cable Ribbon cable, optional use (up to 4)	250 gr

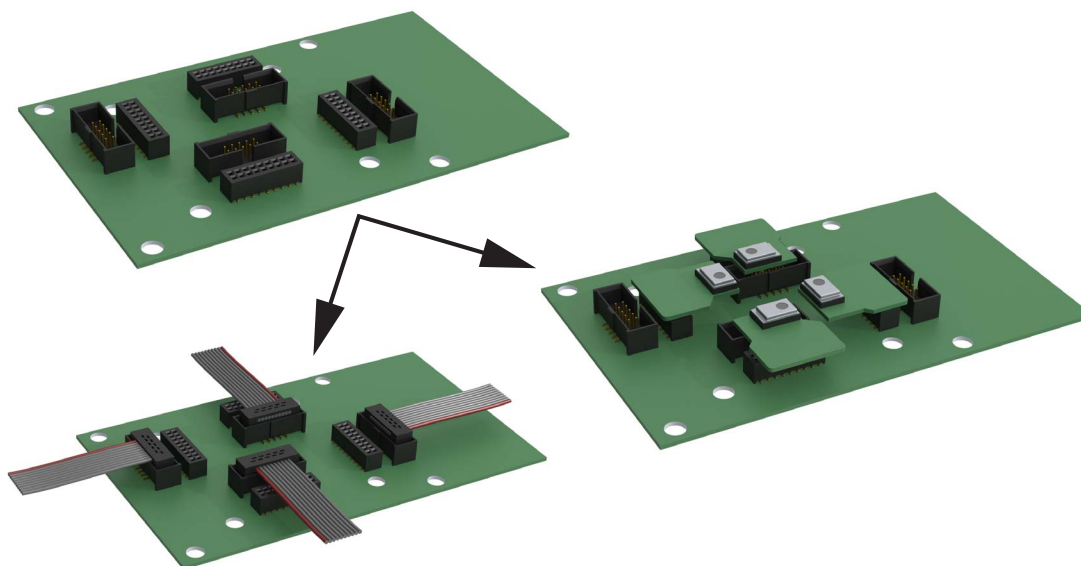

USEQCSK0000000 can flexibly host up to four modules. With no hardware design work required, a combination of this backplane board and any of the attached SMD sensors can produce infrared sensor signal measurements out of the box in the early evaluation and design stages. This control board is provided with PC software allowing the user to configure and read each of the SMD sensors connected. The sensor data is visualised in real time on a scope plot in the user interface. A csv file capture facility records the digital signals from the sensors for further processing by the user.

Evaluation Kits cont.

Evaluation Kits

- Quick prototype development
- Easy way to evaluate
- Easy to install software
- Digital output

The digital SMD Flame Sensing kit is to enable the users to carry out a simple and effective evaluation of the KEMET QFS SMD flame sensors, experiment with the sample flame detection ratio based algorithm, and to capture measured data to a PC. The kit is based on the ST microelectronics STM32F303K8 microcontroller with a high precision A-D converter and programmable gain amplifier.

Part Number	Use	Includes	Weight
 USEQFSK1000000	Digital SMD Flame Sensing Evaluation Kit	USEQFS prototype flame sensing detector Sensor USEQFSEA50L180 1p x 5.00 μm LWP filter Sensor USEQFSEA391180 1p x 3.91 μm / 90 nm filter Sensor USEQFSEA464180 1p x 4.64 μm / 180 nm filter Sensor USEQFSEA448180 1p x 4.48 μm / 620 nm filter USB communications cable	350 gr

Packaging

Part Number	Packaging Type	Piece per Bag
USEQFSM*****	ESD Protective Bag	1

Part Number	Packaging Type	Piece per Box
USEQFSK1000000	Cardboard Box	1

Алматы (7273)495-231
 Ангарск (3955)60-70-56
 Архангельск (8182)63-90-72
 Астрахань (8512)99-46-04
 Барнаул (3852)73-04-60
 Белгород (4722)40-23-64
 Благовещенск (4162)22-76-07
 Брянск (4832)59-03-52
 Владивосток (423)249-28-31
 Владикавказ (8672)28-90-48
 Владимир (4922)49-43-18
 Волгоград (844)278-03-48
 Вологда (8172)26-41-59
 Воронеж (473)204-51-73
 Екатеринбург (343)384-55-89

Россия +7(495)268-04-70

Иваново (4932)77-34-06
 Ижевск (3412)26-03-58
 Иркутск (395)279-98-46
 Казань (843)206-01-48
 Калининград (4012)72-03-81
 Калуга (4842)92-23-67
 Кемерово (3842)65-04-62
 Киров (8332)68-02-04
 Коломна (4966)23-41-49
 Кострома (4942)77-07-48
 Краснодар (861)203-40-90
 Красноярск (391)204-63-61
 Курск (4712)77-13-04
 Курган (3522)50-90-47
 Липецк (4742)52-20-81

Казахстан +7(7172)727-132

Магнитогорск (3519)55-03-13
 Москва (495)268-04-70
 Мурманск (8152)59-64-93
 Набережные Челны (8552)20-53-41
 Нижний Новгород (831)429-08-12
 Новокузнецк (3843)20-46-81
 Ноябрьск (3496)41-32-12
 Новосибирск (383)227-86-73
 Киров (8332)68-02-04
 Омск (3812)21-46-40
 Орел (4862)44-53-42
 Оренбург (3532)37-68-04
 Пенза (8412)22-31-16
 Петрозаводск (8142)55-98-37
 Псков (8112)59-10-37
 Пермь (342)205-81-47

Киргизия +996(312)96-26-47

Ростов-на-Дону (863)308-18-15
 Рязань (4912)46-61-64
 Самара (846)206-03-16
 Саранск (8342)22-96-24
 Санкт-Петербург (812)309-46-40
 Саратов (845)249-38-78
 Севастополь (8692)22-31-93
 Симферополь (3652)67-13-56
 Смоленск (4812)29-41-54
 Сочи (862)225-72-31
 Ставрополь (8652)20-65-13
 Сургут (3462)77-98-35
 Сыктывкар (8212)25-95-17
 Тамбов (4752)50-40-97
 Тверь (4822)63-31-35

Тольятти (8482)63-91-07
 Томск (3822)98-41-53
 Тула (4872)33-79-87
 Тюмень (3452)66-21-18
 Ульяновск (8422)24-23-59
 Улан-Удэ (3012)59-97-51
 Уфа (347)229-48-12
 Хабаровск (4212)92-98-04
 Чебоксары (8352)28-53-07
 Челябинск (351)202-03-61
 Череповец (8202)49-02-64
 Чита (3022)38-34-83
 Якутск (4112)23-90-97
 Ярославль (4852)69-52-93