

Overview

KEMET's QGC thin film pyroelectric gas sensors can be reduced in physical size and still provide high sensitivity with fast frequency operation, enabling this highly stable 1 to 4 element sensor in a TO39 package.

The sensor element is built into a low noise circuit that has an internal CMOS operational amplifier with a 10 GΩ feedback resistor outputting a voltage signal centred around half the supply rail.

Applications

- Gas and gas flues
- HVAC (refrigerant or CO₂-driven ventilation system)
- Industrial process and safety
- Medical capnography and anesthesia
- Handheld breath analysis and breath rate measurement
- Breath actuated dispenser
- Automotive cabin air quality
- Exhaust (CO₂ content)
- Home and building technology
- Environmental monitoring (ambient CO₂ level)
- Pollution air quality in home, office and car (excessive CO₂ level)

Benefits

- Fast, stable response over a wide operating frequency range
- 1, 2, or 4 sensor elements in one package
- TO39 package
- Analog output
- Various optical filter options
- Integrated operational amplifier
- Evaluation kit 5 for Analog TO CO₂ gas sensing evaluation

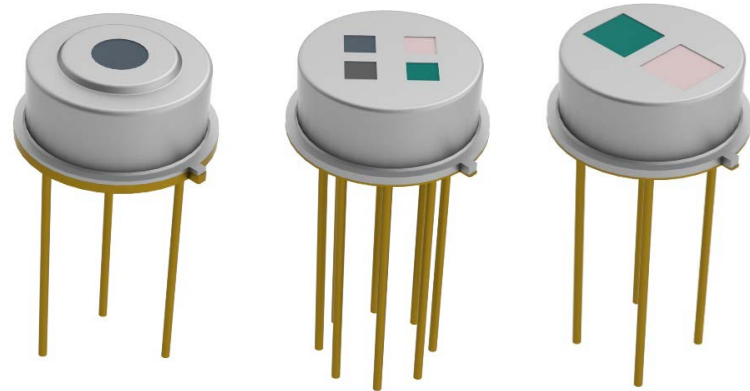

Алматы (7273)495-231
Ангарск (3955)60-70-56
Архангельск (8182)63-90-72
Астрахань (8512)99-46-04
Барнаул (3852)73-04-60
Белгород (4722)40-23-64
Благовещенск (4162)22-76-07
Брянск (4832)59-03-52
Владивосток (423)249-28-31
Владикавказ (8672)28-90-48
Владимир (4922)49-43-18
Волгоград (844)278-03-48
Вологда (8172)26-41-59
Воронеж (473)204-51-73
Екатеринбург (343)384-55-89

Россия +7(495)268-04-70

Иваново (4932)77-34-06
Ижевск (3412)26-03-58
Иркутск (395)279-98-46
Казань (843)206-01-48
Калининград (4012)72-03-81
Калуга (4842)92-23-67
Кемерово (3842)65-04-62
Киров (8332)68-02-04
Коломна (4966)23-41-49
Кострома (4942)77-07-48
Краснодар (861)203-40-90
Красноярск (391)204-63-61
Курск (4712)77-13-04
Курган (3522)50-90-47
Липецк (4742)52-20-81

Казахстан +7(7172)727-132

Магнитогорск (3519)55-03-13
Москва (495)268-04-70
Мурманск (8152)59-64-93
Набережные Челны (8552)20-53-41
Нижний Новгород (831)429-08-12
Новокузнецк (3843)20-46-81
Ноябрьск (3496)41-32-12
Новосибирск (383)227-86-73
Омск (3812)21-46-40
Орел (4862)44-53-42
Оренбург (3532)37-68-04
Пенза (8412)22-31-16
Петрозаводск (8142)55-98-37
Псков (8112)59-10-37
Пермь (342)205-81-47

Киргизия +996(312)96-26-47

Ростов-на-Дону (863)308-18-15
Рязань (4912)46-61-64
Самара (846)206-03-16
Саранск (8342)22-96-24
Санкт-Петербург (812)309-46-40
Саратов (845)249-38-78
Севастополь (8692)22-31-93
Симферополь (3652)67-13-56
Смоленск (4812)29-41-54
Сочи (862)225-72-31
Ставрополь (8652)20-65-13
Сургут (3462)77-98-35
Сыктывкар (8212)25-95-17
Тамбов (4752)50-40-97
Тверь (4822)63-31-35

Тольятти (8482)63-91-07
Томск (3822)98-41-53
Тула (4872)33-79-87
Тюмень (3452)66-21-18
Ульяновск (8422)24-23-59
Улан-Удэ (3012)59-97-51
Уфа (347)229-48-12
Хабаровск (4212)92-98-04
Чебоксары (8352)28-53-07
Челябинск (351)202-03-61
Череповец (8202)49-03-64
Чита (3022)38-34-83
Якутск (4112)23-90-97
Ярославль (4852)69-52-93

Ordering Information

USE	QGC	C	A	REF1		0	0
Product Family	Series	Sensor Type	Mounting Type	Specification		Packaging	Version
Sensors	QGC = TO39 IR Gas Sensors	C = Circle D = Dual Q = Quad K = Evaluation kit	A = Sensor only 5 = Kit type 5	0000 = Fixed REF1 = Reference C82L = CO ₂ C82S = CO ₂ Special C82N = CO ₂ Narrow C82M = CO ₂ Medical C821 = CO ₂ Medical C8L1 = CO C8N1 = CO Narrow CH41 = CH ₄ N8L1 = NO	HC11 = H-C (1) HC21 = H-C (2) S821 = SO ₂ R121 = Refrigerant R12 (Freon) 50L1 = Broadband (5µm Long Pass) ANA1 = Anesthesia (Dual) N821 = NO ₂ SF61 = SF ₆ , Ethylene C82H = CO ₂ , CO, CH ₄ , NDIR AN11 = Anesthesia (Quad 1) AN21 = Anesthesia (Quad 2) EXH1 = Exhaust, Environmental	0 = Bulk	0

Environmental Compliance

All KEMET Gas Sensors are RoHS and REACH Compliant.



Article 33(1) of the REACH Regulation states that manufacturers and importers of articles (products) are required to notify their customers of the presence of any Substances of Very High Concern (SVHC) in their products exceeding 0.1% by weight and provide instructions on safe use of the product.

KEMET Corporation reports regarding the Article 33(1) of REACH Regulation as follows:

1. *Applicable Product: Gas Sensors (QGC, QGS & QGSM series)*

2. *Report for the content of REACH SVHC list:*

The product(s) above contains a substance by more than 0.1wt% per product weight that was published in the 8th update of the REACH SVHC substances (December 19, 2012).

3. *Regarding the safety of the gas sensors (Piezoceramic products):*

The Piezoceramic that is used in this product becomes ceramic by sintering powder containing PZT as the main ingredient. It is chemically stable, with minimum risks toward the human body or environment within the intended use of the product. Please note that risks could occur in the case of inhalation or accidental oral uptake of powder ceramics.

4. *Technical product information on the gas sensors (Piezoceramic products):*

The manufacturing technique of the "piezoceramic products" whose main ingredient is Lead Titanium Zirconium Oxide (PZT) has been established, and there is no alternative material that can exhibit superior performance than PZT at this moment. Please note that the piezoceramic is listed as an exempt on RoHS (2011/65/EU) AnnexIII (7c.1).

5. *The responsibility of piezoceramic manufacturers:*

Piezoceramic manufacturers report information regarding PZT containment in their products to the customers to obey the article 33 of the REACH regulation

Infrared Spectroscopy

KEMET Infrared Sensors work in the MID Infrared Spectrum. They are a critical component -- but not the only component -- in a gas analysis system. An IR heat source and a suitable gas path “mechanical enclosure” are also required in order to complete the gas analysis system.

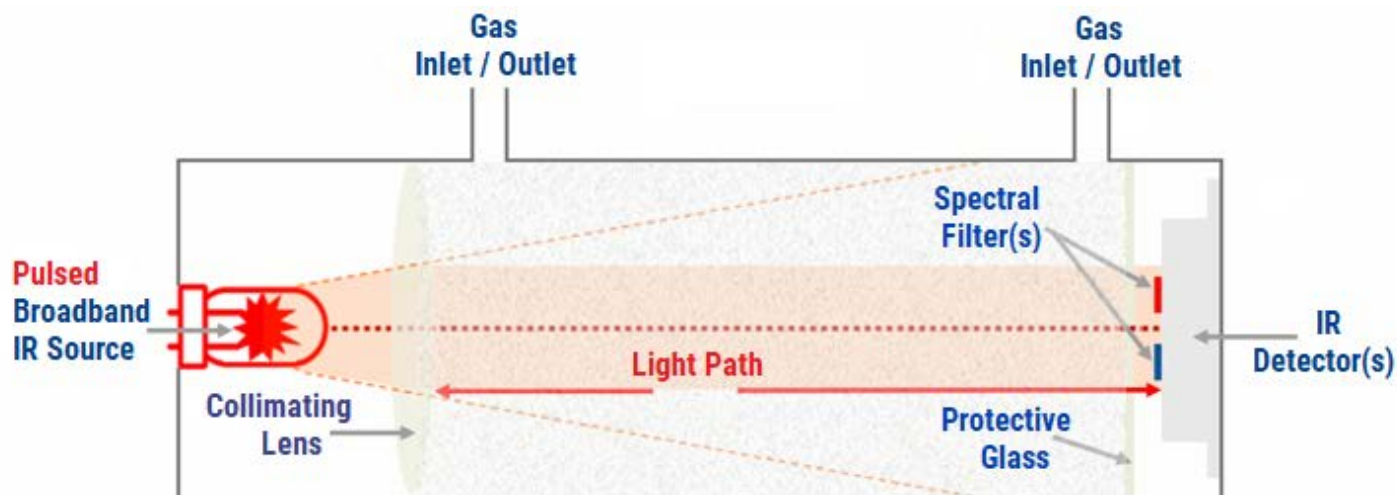

IR Absorption - Active IR Sensing

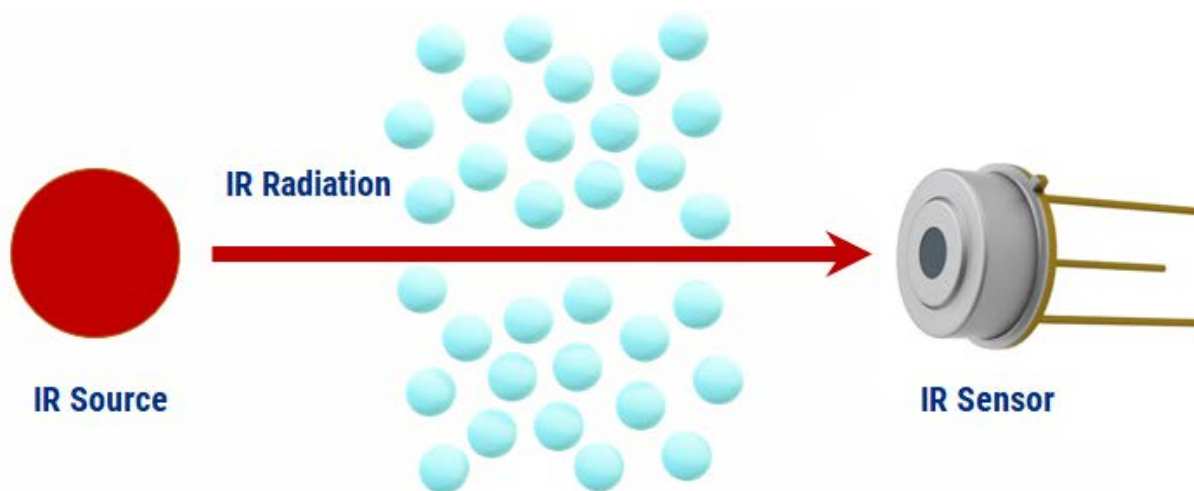

The IR source is directed as energy towards the sensor like an IR spotlight. Depending on the specific gas of interest or gas concentration levels between the IR source and the pyroelectric sensor, the IR transmitted is absorbed by the presence of the gas by a small amount. Understanding how much IR is being optically transmitted versus how much is received can indicate gas concentration levels.

Filters are used to shorten the optical spectrum of the sensor to specifically match the gas of interest. These filters are usually included within the sensor, but for special cases KEMET can make optimised filters to suit customers specific gas requirements.

Dimensions – Millimeters

Single Sensor

Cross Section View

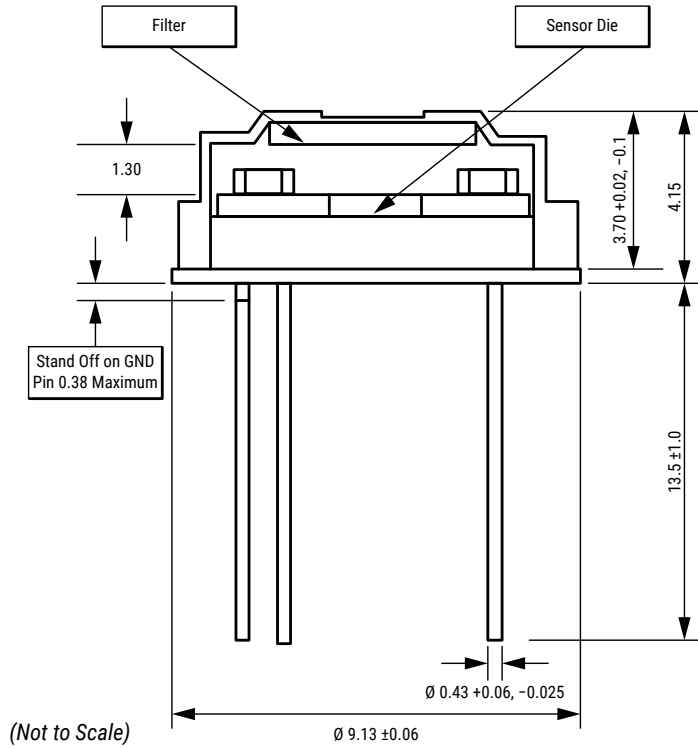

Top View

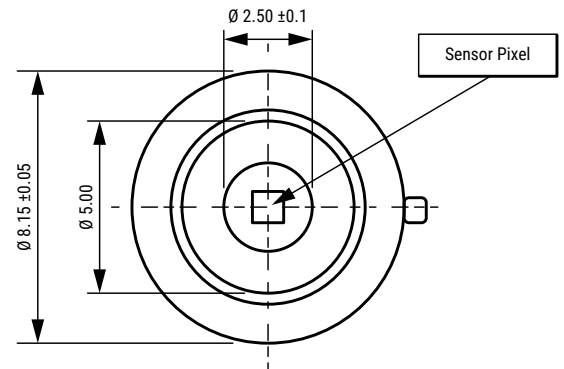

Bottom View

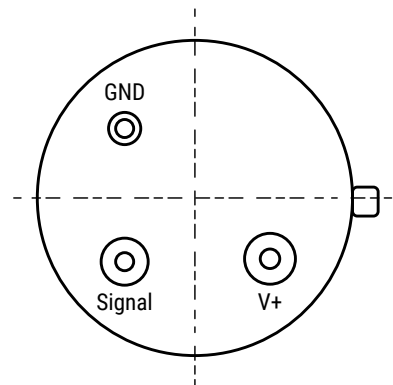

Dimensions – Millimeters cont.

Dual Sensor

Cross Section View

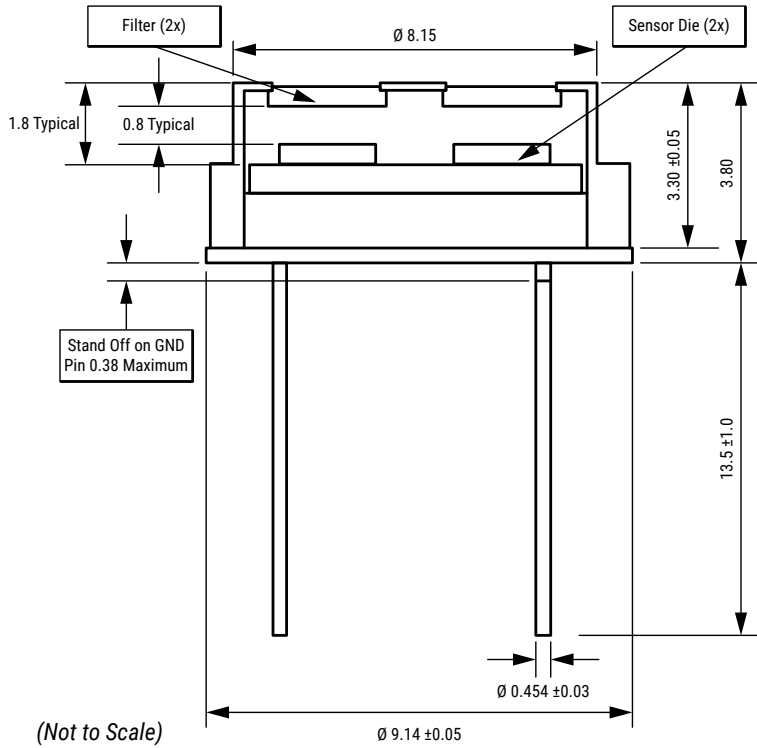

Top View

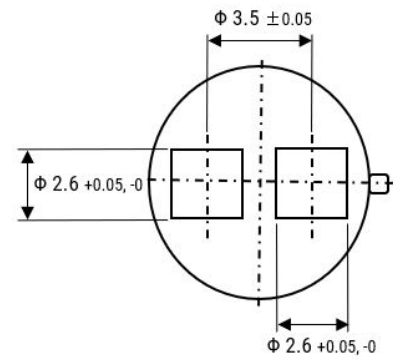

Bottom View

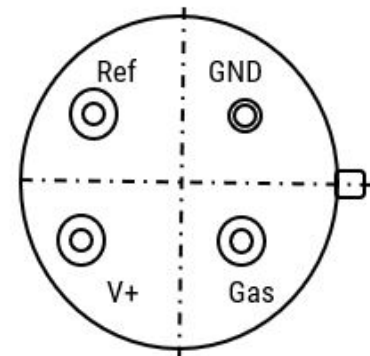

Dimensions – Millimeters cont.

Quad Sensor

Cross Section View

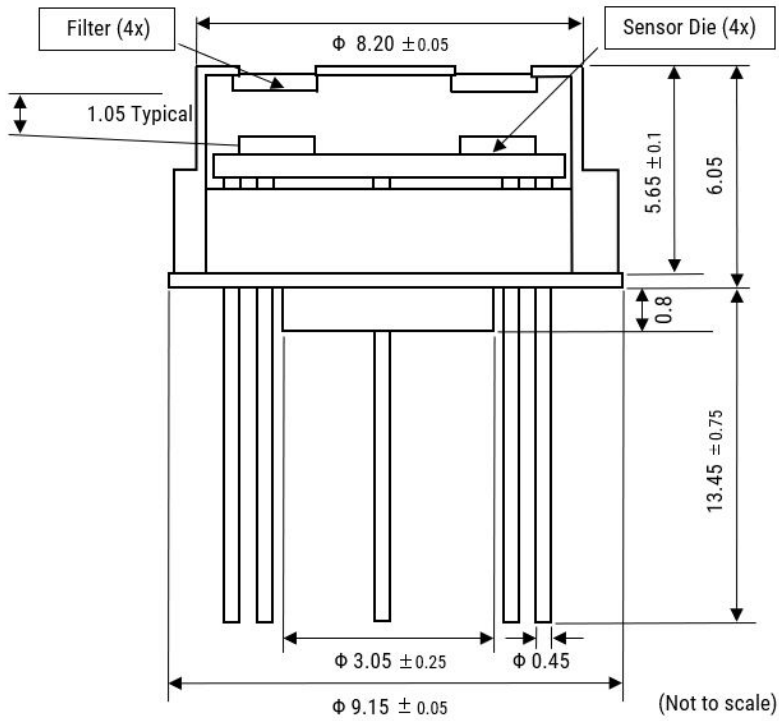

Top View

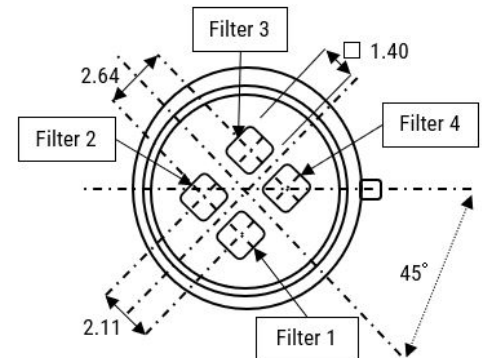

Bottom View

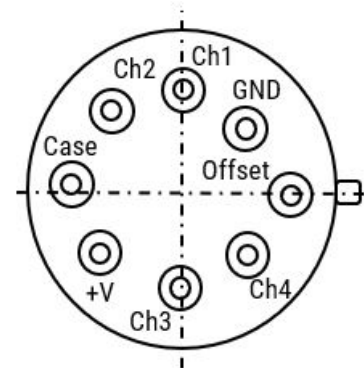

Recommended Circuit Diagram

Single Sensor

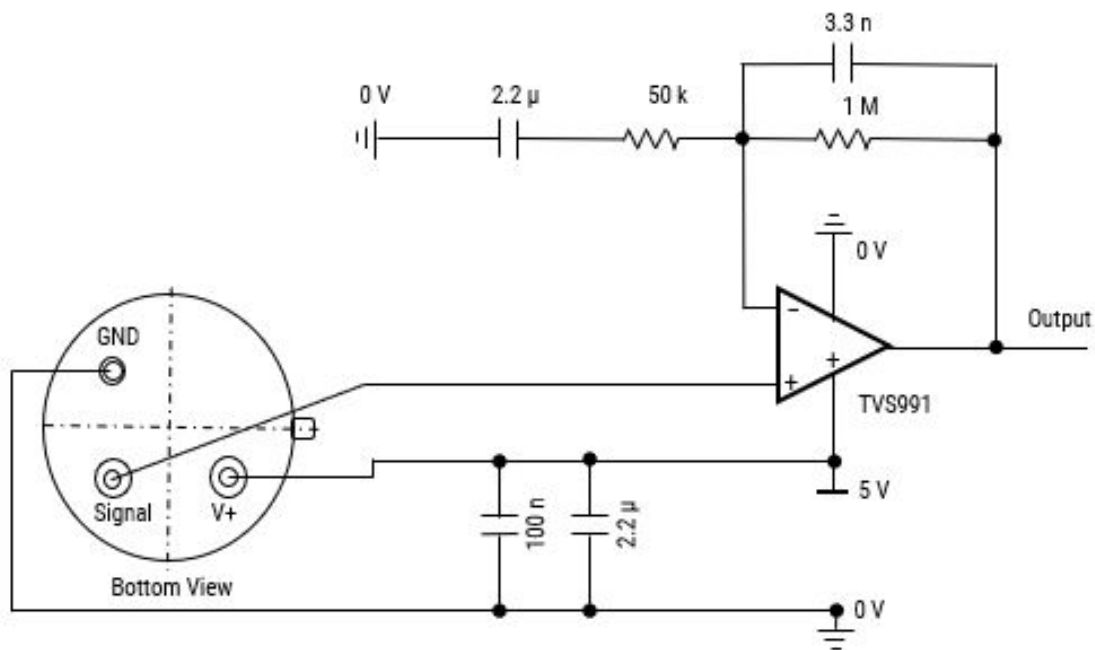

Dual Sensor

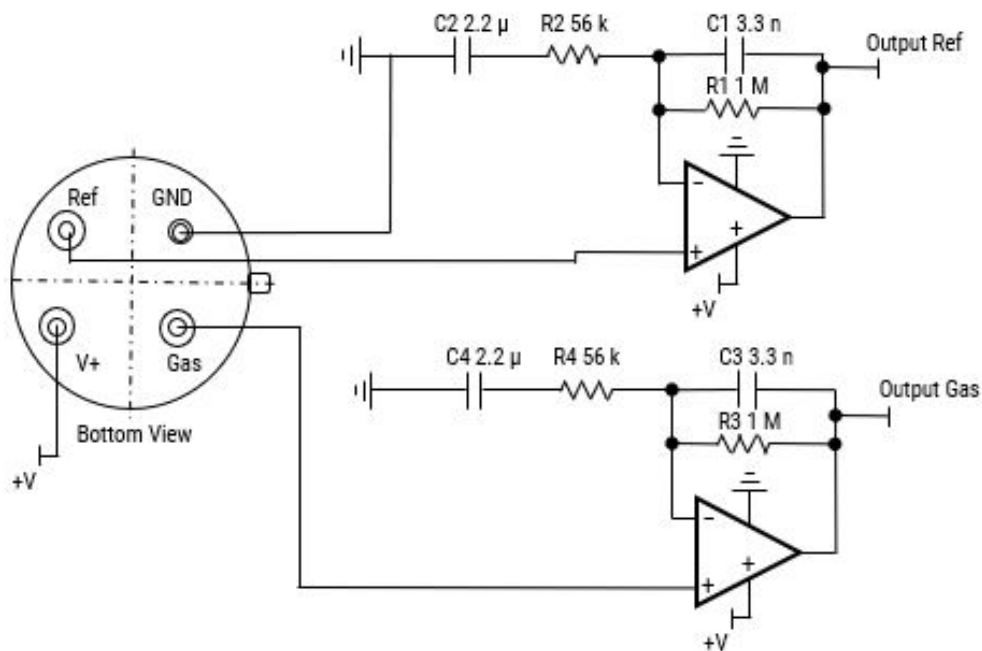

Recommended Circuit Diagram cont.

Quad Sensor

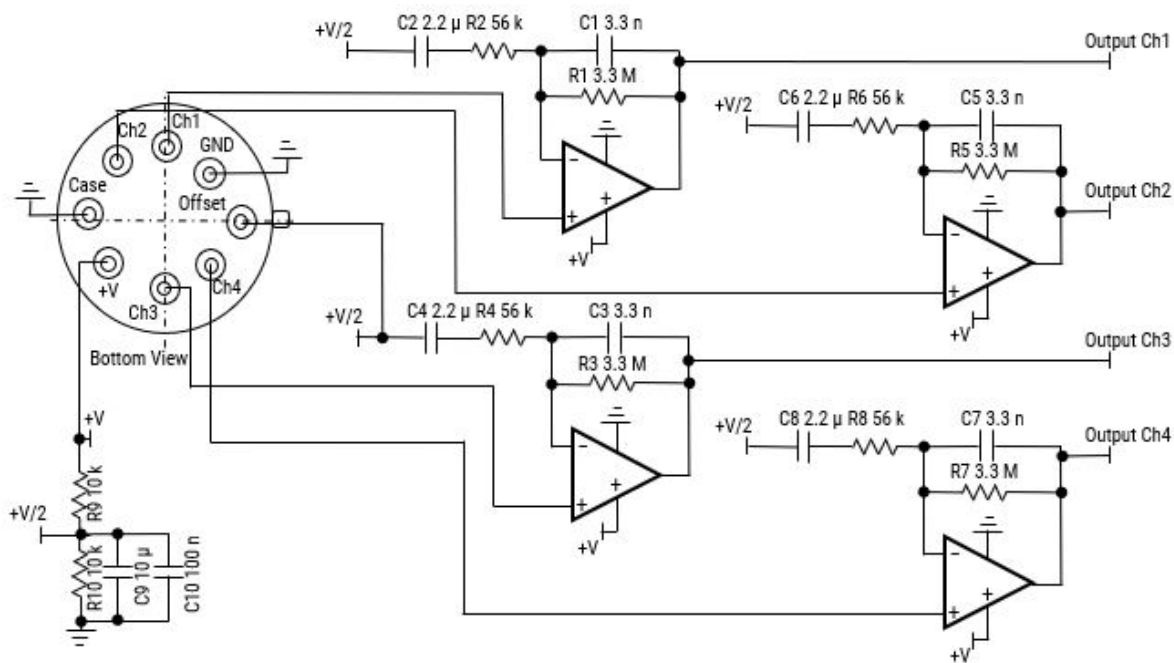

Performance Characteristics

Single & Dual Sensor

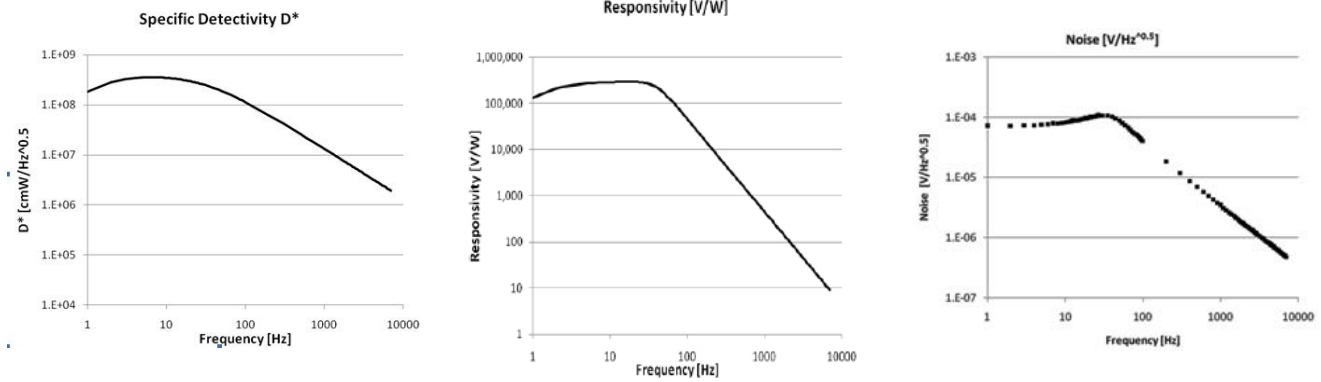

Quad Sensor

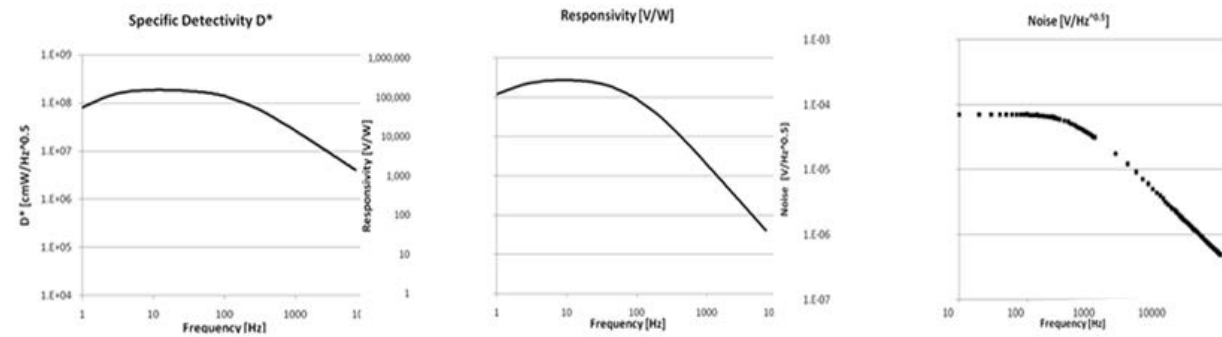

Part Number Specifications

Sensor Characteristics

Channel	Filter Aperture (mm)	Element Size (μm)	Package	Responsivity ¹ (V/W)	D* ¹ (cm√Hz/W)	Noise ¹ (μV/√Hz)
Single sensor	2.5 ∅	1,000 x 1,000	T039	150,000	3.5 x 10 ⁸	Mean 70
Dual sensor	2.6 x 2.6					
Quad sensor	0.7 x 0.325			100,000	1.5 x 10 ⁸	Mean 40

¹ 10 Hz, 500 K, room temperature, without window and optics.

Electrical Characteristics

Channel	Maximum Voltage ¹ (V)	Minimum Voltage (V)	Microphonics (μV/√Hz) at 10 Hz	Time Constant (ms)	Operating Temperature Range (°C)	Storage Temperature Range (°C)	Recommended offset Voltage (V)	Maximum offset Voltage (V)	Minimum offset Voltage (V)
Single sensor	8	2.7	S _{vib} ~2	~12	-40 to +85	-40 to +110	-	-	-
Dual sensor									
Quad sensor	5 ^{2&3}		S _{vib} ~1	~10			+V/2 ²	+V-0.1 ²	0.1 ²

¹ Absolute maximum operating voltage.

² With reference to GND.

³ Absolute maximum operating voltage 6.0 V.

Output voltage normalised around mid-rail.

Op-Amp with 10 GΩ feedback resistor.

Part Number (Single Sensor)

Part Number	Channel 1	Use	Weight (gr)
	CWL μm / (HPB nm)		
USEQGCCAREF100	3.91 / (90)	Reference	0.93
USEQGCCAC82L00	4.26 / (180)	CO ₂	0.93
USEQGCCAC82S00	4.43 / (60)	CO ₂ (Special)	0.93
USEQGCCAC82N00	4.30 / (110)	CO ₂ (Narrow)	0.93
USEQGCCAC8L100	4.64 / (180)	CO	0.93
USEQGCCAC8N100	4.64 / (90)	CO (Narrow)	0.93
USEQGCCACH4100	3.30 / (160)	CH ₄	0.93
USEQGCCAN8L100	5.30 / (180)	NO	0.93
USEQGCCAHC1100	3.375 / (190)	H-C	0.93
USEQGCCAS82100	7.30 / (200)	SO ₂	0.93
USEQGCCAR12100	10.35 / (190)	Refrigerant R12 (Freon)	0.93
USEQGCCA50L100	5.0 Long Pass	Broadband for bespoke filters	0.93

Part Number Specifications cont.

Part Number (Dual Sensor)

Part Number	Channel 1	Channel 2	Use	Weight (gr)
	CWL μm / (HPB nm)			
USEQGCDAC82L00	3.91 / (90)	4.26 / (180)	CO ₂	0.97
USEQGCDAC82S00	3.91 / (90)	4.43 / (60)	CO ₂ (Special)	0.97
USEQGCDAC82N00	3.91 / (90)	4.30 / (110)	CO ₂ (Narrow)	0.97
USEQGCDAC82M00	3.70 / (110)	4.26 / (180)	CO ₂ (Medical)	0.97
USEQGCDAC82100	4.90 / (130)	4.26 / (180)	CO ₂ (Medical)	0.97
USEQGCDAC8L100	3.91 / (90)	4.64 / (180)	CO	0.97
USEQGCDAC8N100	3.91 / (90)	4.64 / (90)	CO (Narrow)	0.97
USEQGCDACH4100	3.91 / (90)	3.30 / (160)	CH ₄	0.97
USEQGCDAN8L100	3.91 / (90)	5.30 / (180)	NO	0.97
USEQGCDAHC1100	3.91 / (90)	3.33 / (160)	H-C (1)	0.97
USEQGCDAHC2100	3.91 / (90)	3.375 / (190)	H-C (2)	0.97
USEQGCDAS82100	3.91 / (90)	7.30 / (200)	SO ₂	0.97
USEQGCDAR12100	8.94 / (225)	10.36 / (190)	Refrigerant R12 (Freon)	0.97
USEQGDA50L100	5.0 Long Pass	5.0 Long Pass	Broadband for bespoke filters	0.97
USEQGDAANA100	8.44 / (205)	4.26 / (180)	Anesthesia	0.97
USEQGCDAN82100	3.91 / (90)	6.20 / (200)	NO ₂	0.97
USEQGCDASF6100	3.91 / (90)	10.6 / (240)	SF ₆ , Ethylene	0.97

Part Number (Quad Sensor)

Part Number	Channel 1	Channel 2	Channel 3	Channel 4	Use	Weight (gr)
	CWL μm / (HPB nm)					
USEQGCQAC82H00	3.38 / (190)	3.91 / (90)	4.26 / (180)	4.64 / (180)	HC, CO, CO ₂	1.15
USEQGCQAAN1100	3.90 / (200)	3.90 / (200)	4.26 / (180)	8.416 / (180)	Anesthesia (1)	1.15
USEQGCQAAN2100	8.75 / (200)	9.62 / (230)	12.25 / (210)	8.55 / (180)	Anesthesia (2)	1.15
USEQGCQAEXH100	4.26 / (180)	4.64 / (180)	3.30 / (160)	3.91 / (90)	Exhaust, Environmental	1.15

Evaluation Kits

- Quick prototype development
- Easy way to evaluate
- Easy to install software
- Digital output

The analog TO CO₂ Gas Sensing Evaluation kit is to enable the users to carry out a simple and effective demonstration of the QGC two channel CO₂ sensor, as well as to provide a flexible platform to start evaluation and design work with all others QGC TO-39 packaged gas sensors.

Part Number	Use	Includes	Weight (gr)
USEQGCK5000000	Analog TO CO ₂ Gas Sensing Evaluation Kit	PCB with C8051F350 microcontroller and ADC USEQGDAC82L00, dual channel CO ₂ sensor Emitter drive PCB, with TO-39 IR emitter, reflector and sapphire window Brass gas cell ¹ 9 V DC power supply USB communications cable	250

1 Not gas sealed, please consider safety if used with toxic gases.



Part Schematic cont.

Internal Schematics cont.

Quad Sensor

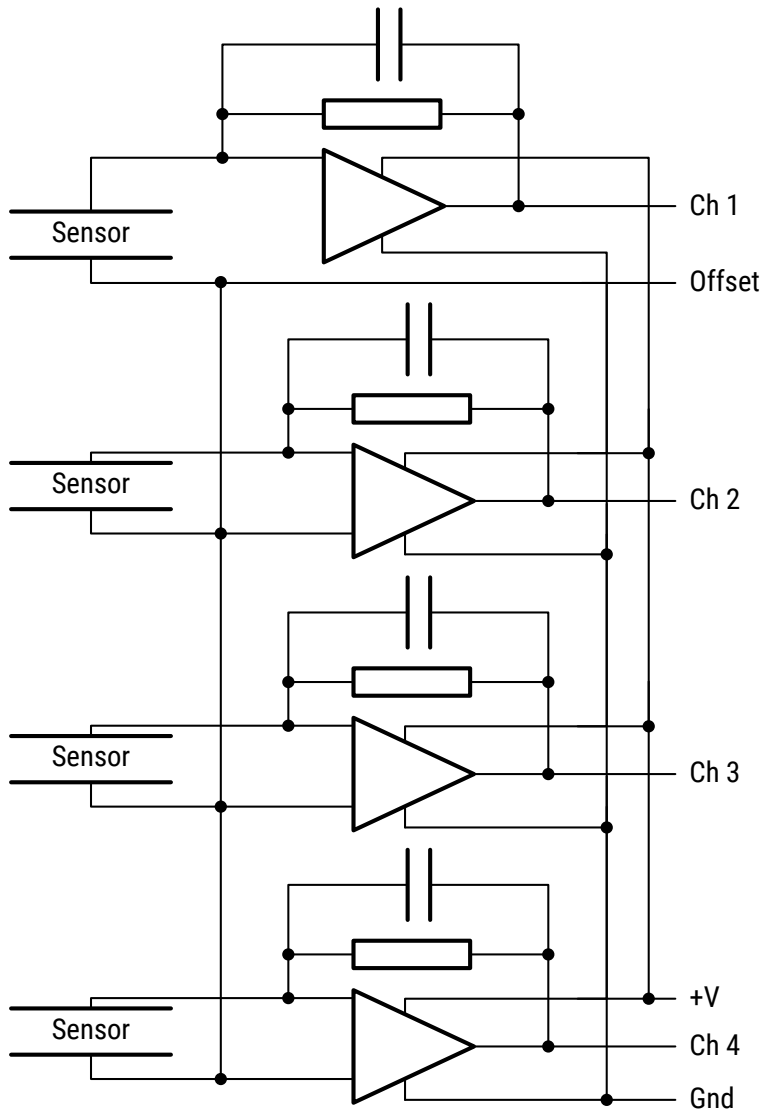

Packaging

Part Number	Packaging Type	Pieces Per Tube
USEQGCC*****	Tube	50
USEQGCD*****		
USEQGCQ*****		

Part Number	Packaging Type	Piece Per Box
USEQGCK5000000	Cardboard Box	1

Handling Precautions

Pyroelectric Infrared Sensors should be kept away from indirect and direct sunlight, the headlights of cars, wind, and exposure to strong vibration and strong shock.

Do not use in water, alcohol ETA, corrosive gas or under sea breeze.

Do not be expose to corrosive substances.

Do not drop or apply any mechanical stress.

The performance of this device can be affected by ESD. Precautions should be used when handling and installing the sensor. Precision devices such as this sensor can be damaged or caused not to meet published specification due to ESD. Please note that there is limited ESD protection built-in as the device is optimised for low power consumption and low noise operation. Human Body Model (HBM), per JS-001: 2,000 V.

Pyroelectric Infrared Sensors should be stored in normal working environments.

Solderability will be degraded by exposure to high temperatures, high humidity, corrosive atmospheres, and long-term storage.

KEMET recommends that ambient storage conditions are < 30°C and < 60% relative humidity and that maximum storage temperature does not exceed 110°C. Atmospheres should be free of chlorine and sulfur-bearing compounds.

Temperature fluctuations should be minimized to avoid condensation on the parts.

For optimized solderability sensors stock should be used promptly, preferably within 24 months of receipt.

Алматы (7273)495-231
 Ангарск (3955)60-70-56
 Архангельск (8182)63-90-72
 Астрахань (8512)99-46-04
 Барнаул (3852)73-04-60
 Белгород (4722)40-23-64
 Благовещенск (4162)22-76-07
 Брянск (4832)59-03-52
 Владивосток (423)249-28-31
 Владикавказ (8672)28-90-48
 Владимир (4922)49-43-18
 Волгоград (844)278-03-48
 Вологда (8172)26-41-59
 Воронеж (473)204-51-73
 Екатеринбург (343)384-55-89

Россия +7(495)268-04-70

Иваново (4932)77-34-06
 Ижевск (3412)26-03-58
 Иркутск (395)279-98-46
 Казань (843)206-01-48
 Калининград (4012)72-03-81
 Калуга (4842)92-23-67
 Кемерово (3842)65-04-62
 Киров (8332)68-02-04
 Коломна (4966)23-41-49
 Кострома (4942)77-07-48
 Краснодар (861)203-40-90
 Красноярск (391)204-63-61
 Курск (4712)77-13-04
 Курган (3522)50-90-47
 Липецк (4742)52-20-81

Казахстан +7(7172)727-132

Магнитогорск (3519)55-03-13
 Москва (495)268-04-70
 Мурманск (8152)59-64-93
 Набережные Челны (8552)20-53-41
 Нижний Новгород (831)429-08-12
 Новокузнецк (3843)20-46-81
 Ноябрьск (3496)41-32-12
 Новосибирск (383)227-86-73
 Омск (3812)21-46-40
 Орел (4862)44-53-42
 Оренбург (3532)37-68-04
 Пенза (8412)22-31-16
 Петрозаводск (8142)55-98-37
 Псков (8112)59-10-37
 Пермь (342)205-81-47

Киргизия +996(312)96-26-47

Ростов-на-Дону (863)308-18-15
 Рязань (4912)46-61-64
 Самара (846)206-03-16
 Саратов (8342)22-96-24
 Санкт-Петербург (812)309-46-40
 Саратов (845)249-38-78
 Севастополь (8692)22-31-93
 Симферополь (3652)67-13-56
 Смоленск (4812)29-41-54
 Сочи (862)225-72-31
 Ставрополь (8652)20-65-13
 Сургут (3462)77-98-35
 Сыктывкар (8212)25-95-17
 Тамбов (4752)50-40-97
 Тверь (4822)63-31-35

Тольятти (8482)63-91-07
 Томск (3822)98-41-53
 Тула (4872)33-79-87
 Тюмень (3452)66-21-18
 Ульяновск (8422)24-23-59
 Улан-Удэ (3012)59-97-51
 Уфа (347)229-48-12
 Хабаровск (4212)92-98-04
 Чебоксары (8352)28-53-07
 Челябинск (351)202-03-61
 Череповец (8202)49-02-64
 Чита (3022)38-34-83
 Якутск (4112)23-90-97
 Ярославль (4852)69-52-93