

## Overview

The Piezoelectric Haptic Modules (Film Flex Assembled Actuators) are revolutionary, next-generation flexible haptics actuator technology with the unique ability to provide localized, bodily sensations and tactile effects currently unavailable with any other product in the market. These versatile actuators can be used in a broad range of applications including AR/VR, gaming controllers, as well as in visionary products of the future that leverage human-computer interaction.

This is made possible by the thin form factor, ideal size and flexibility of the actuators.

With these Piezoelectric Haptic Modules the haptic skin technology designers can add the sense of touch to the surface of products providing:

- localized, independent sensations that enhance user experience,
- natural, organic, authentic touch sensations,
- programmable, customizable effects providing a unique range of sensations.

## Benefits

- Extremely thin and flexible - enabling them to be conformally embedded into a variety surfaces for many applications to provide high quality haptic feedback
- Multi-location effects - whereby multiple actuators can be applied to different locations of the same surface and vibrated in a desired order to deliver a plurality of feedback approaches that combine pattern recognition and effect recognition.
- Wide frequency range provides haptic feedback - programmable haptic feedback that feels natural, providing a rich user experience
- Providing a natural sense of touch
- Increasing sense of realism and better tactile feedback
- Enhancing user satisfaction
- RoHS and REACH compliant

## Applications

Products with hand contact:

- AR (Augmented Reality) and VR (Virtual Reality)
- Remote control
- Gaming controller
- Medical controller
- Smart textiles
- Mouse
- User interface capacitive touch surface

Products with lips contact:

- Musical instrument (mouth piece)
- Medical equipment

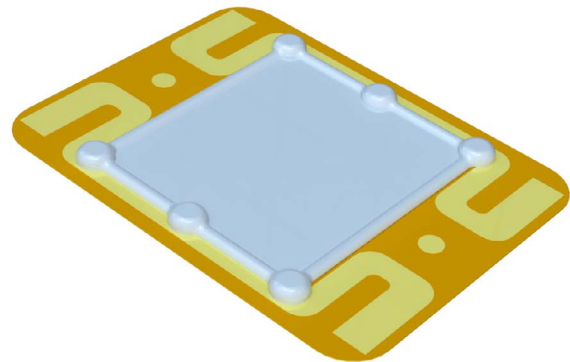

Алматы (7273)495-231  
Ангарск (3955)60-70-56  
Архангельск (8182)63-90-72  
Астрахань (8512)99-46-04  
Барнаул (3852)73-04-60  
Белгород (4722)40-23-64  
Благовещенск (4162)22-76-07  
Брянск (4832)59-03-52  
Владивосток (423)249-28-31  
Владикавказ (8672)28-90-48  
Владимир (4922)49-43-18  
Волгоград (844)278-03-48  
Вологда (8172)26-41-59  
Воронеж (473)204-51-73  
Екатеринбург (343)384-55-89  
Россия +7(495)268-04-70

Иваново (4932)77-34-06  
Ижевск (3412)26-03-58  
Иркутск (395)279-98-46  
Казань (843)206-01-48  
Калининград (4012)72-03-81  
Калуга (4842)92-23-67  
Кемерово (3842)65-04-62  
Киров (8332)68-02-04  
Коломна (4966)23-41-49  
Кострома (4942)77-07-48  
Краснодар (861)203-40-90  
Красноярск (391)204-63-61  
Курск (4712)77-13-04  
Курган (3522)50-90-47  
Липецк (4742)52-20-81  
Казахстан +7(7172)727-132

Магнитогорск (3519)55-03-13  
Москва (495)268-04-70  
Мурманск (8152)59-64-93  
Набережные Челны (8552)20-53-41  
Нижний Новгород (831)429-08-12  
Новокузнецк (3843)20-46-81  
Ноябрьск (3496)41-32-12  
Новосибирск (383)227-86-73  
Омск (3812)21-46-40  
Орел (4862)44-53-42  
Оренбург (3532)37-68-04  
Пенза (8412)22-31-16  
Петрозаводск (8142)55-98-37  
Псков (8112)59-10-37  
Пермь (342)205-81-47  
Киргизия +996(312)96-26-47

Ростов-на-Дону (863)308-18-15  
Рязань (4912)46-61-64  
Самара (846)206-03-16  
Саранск (8342)22-96-24  
Санкт-Петербург (812)309-46-40  
Саратов (845)249-38-78  
Севастополь (8692)22-31-93  
Симферополь (3652)67-13-56  
Смоленск (4812)29-41-54  
Сочи (862)225-72-31  
Ставрополь (8652)20-65-13  
Сургут (3462)77-98-35  
Сыктывкар (8212)25-95-17  
Тамбов (4752)50-40-97  
Тверь (4822)63-31-35

Тольятти (8482)63-91-07  
Томск (3822)98-41-53  
Тула (4872)33-79-87  
Тюмень (3452)66-21-18  
Ульяновск (8422)24-23-59  
Улан-Удэ (3012)59-97-51  
Уфа (347)229-48-12  
Хабаровск (4212)92-98-04  
Чебоксары (8352)28-53-07  
Челябинск (351)202-03-61  
Череповец (8202)49-02-64  
Чита (3022)38-34-83  
Якутск (4112)23-90-97  
Ярославль (4852)69-52-93

## Ordering Information

FFAA	14	19	212	1	1	L
Series	Width (mm)	Length (mm)	Voltage ( $V_{pp}$ )	Actuator Version	Flex Version	Packaging Code
FFAA	14 = 14.1	19 = 18.5	212	1 = V1	1 = See drawing below	L = Tray

## Dimensions in mm

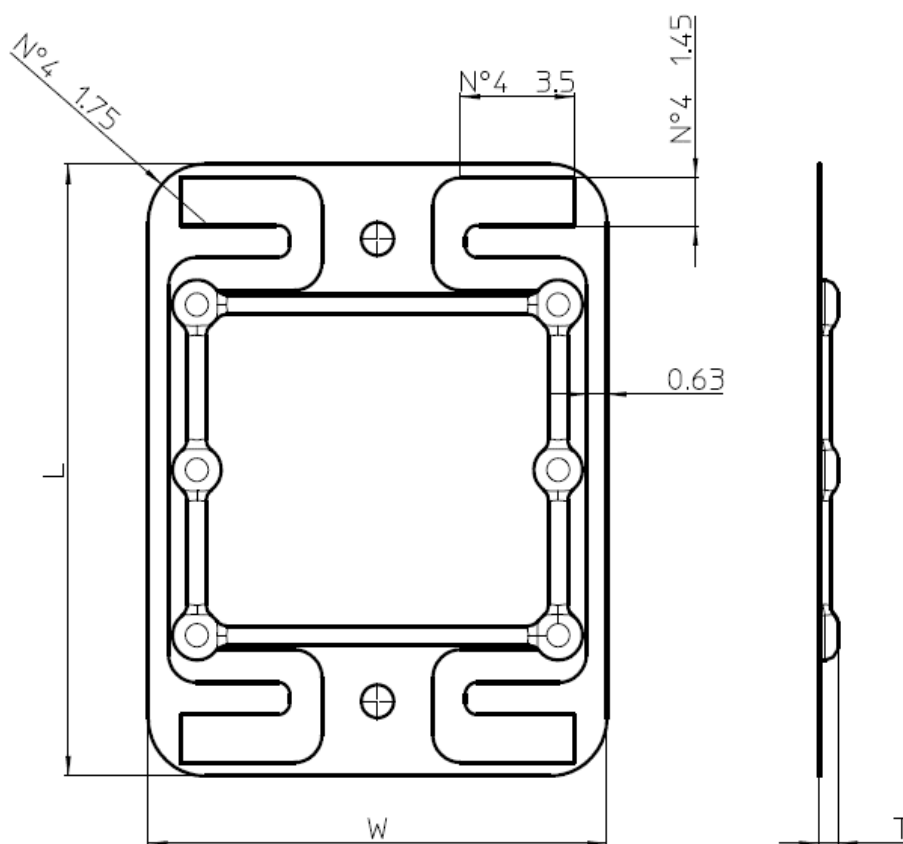

Part Number	Dimensions (mm)		
	W	L	T
FFAA141921211L	14.1 ±0.2	18.5 ±0.2	0.6 ±0.1

## Environmental Compliance

All KEMET Piezoelectric Haptic Film Modules are RoHS and REACH compliant.



## Performance Characteristics

Part Number	Parameter	Symbol	Minimum	Maximum	Description
FFAA141921211L	Stimulus signal voltage	$V_{PP}$	0 V	212 V	Peak-to-peak voltage, all peaks of positive sign
	Frequency	Hz	10 Hz	500 Hz	Voltage frequency
	Peak Inrush Current	$I_{IN}$	-	100 mA	1 msec pulse width
	Slew Rate	dV/dt	-	0.5 V/ $\mu$ sec	
	Storage Temperature	$T_S$	-20°C	+90°C	
	Assembly Temperature	$T_{ASS}$	-	+100°C	
	Operating Temperature	$T_A$	0°C	+60°C	

These Modules can also be offered in a Demo Kit version on RQ, please contact your KEMET sales representative for more information.

### Out of Plane Displacement for Sinusoidal Stimulation at 150 Hz

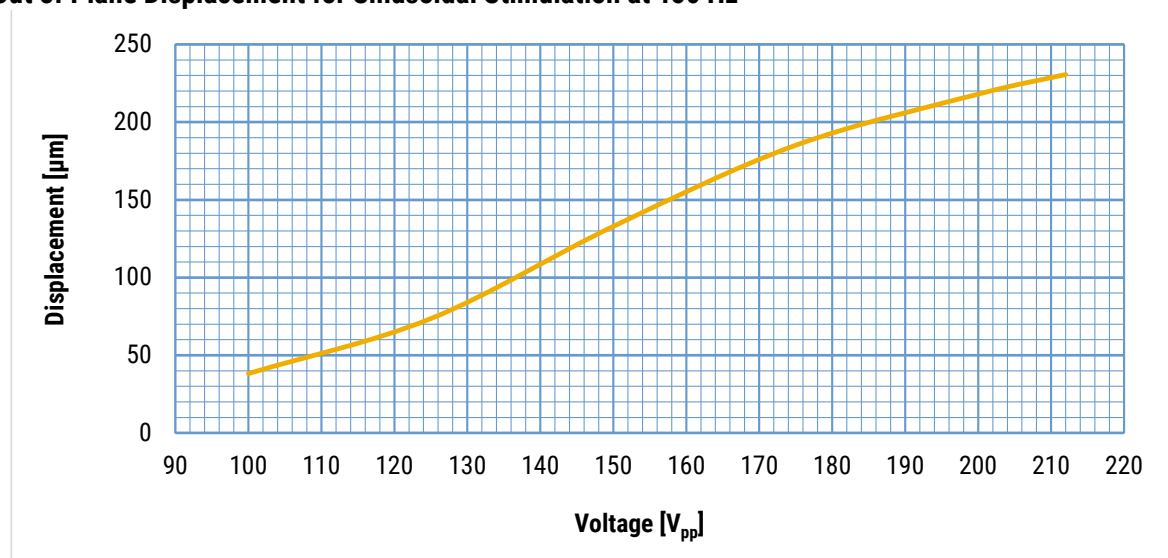

## Environmental Test Data

Storage		
Parameter	Test and Environmental Conditions	Post-Test Result
High Temperature	90°C for 24 hours, non-operating test	Meets the performance characteristics
Low Temperature	-20°C for 24 hours, non-operating test	Meets the performance characteristics
Long Term	25°C, ±5°C for 1 year storage in dry conditions	Meets the performance characteristics
	(< 30% R.H.), non-operating test	

Operating Environment		
Parameter	Test and Environmental Conditions	Post-Test Result
Room Temperature	1 M cycles of 1 second on/3 seconds off; 212 V <sub>pp</sub> 150 Hz 25°C, ±5°C and 50% R.H.	Displacement drop at end of life of -20% (typical)

Non-Operating Environment		
Parameter	Test and Environmental Conditions	Post-Test Result
Thermal Cycling	Modified MIL-STD JESD22 Method JA-104: -20°C <=> +90°C; 5 minute dwell; 1,000 cycles	Meets the performance characteristics

## Packaging

Part Number	Packaging Type	Pieces per Tray	Pieces per Box
FFAA141921211L	Tray	45	180

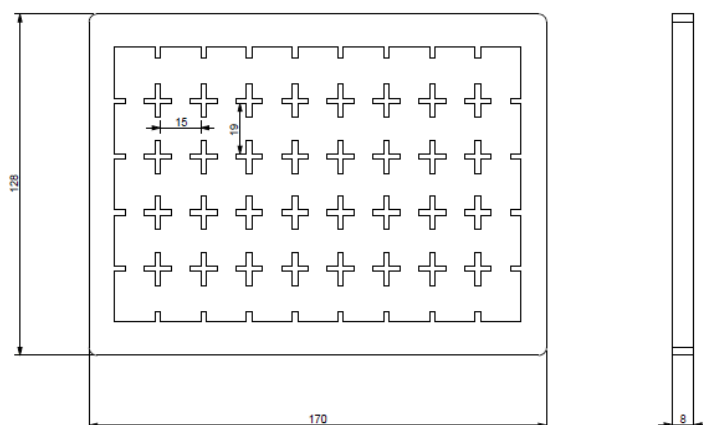

## Handling Precautions

### Precautions to be taken when using Piezoelectric Haptic Modules (Film Flex Assembled Actuators)

Material selection, installation and activation of Piezoelectric Haptic Modules should be decided upon by users according to the applications. For proper evaluation and decision, products should be tested repeatedly in both realistic and abnormal operating conditions.

- Do NOT use near flammable gas or solvent as alcohol, thinner, benzene, gasoline, propane gas due to risk of explosion or fire.
- Do NOT clean with flammable solvent such as alcohol, thinner and benzene due to risk of explosion or fire.
- CAREFULLY apply bending or other mechanical stress as it may change the performance characteristics.
- CAREFULLY apply bending stress during product handling or assembling process.
- Do NOT remodel FFAA Modules to fit into the design.
- Do NOT reuse FFAA modules that have been removed from a assembly unit.
- Do NOT operate or store in dusty high temperature environment, near fire, under strong light or sunshine, in the air containing salt or oil.
- KEMET recommends that maximum storage temperature does not exceed 90°C and maximum storage humidity does not exceed 50% relative humidity and atmospheres should be free of chlorine and sulfur bearing compounds. Temperature fluctuations should be minimized to avoid condensation on the parts.
- KEMET recommends to keep the product inside the dry-pack until its use.

### Integration of the Piezoelectric Haptic Modules (Film Flex Assembled Actuators)

Please contact your KEMET sales representative for more information about the Piezoelectric Haptic Modules integration.

Алматы (7273)495-231  
Ангарск (3955)60-70-56  
Архангельск (8182)63-90-72  
Астрахань (8512)99-46-04  
Барнаул (3852)73-04-60  
Белгород (4722)40-23-64  
Благовещенск (4162)22-76-07  
Брянск (4832)59-03-52  
Владивосток (423)249-28-31  
Владикавказ (8672)28-90-48  
Владимир (4922)49-43-18  
Волгоград (844)278-03-48  
Вологда (8172)26-41-59  
Воронеж (473)204-51-73  
Екатеринбург (343)384-55-89

Россия +7(495)268-04-70

Иваново (4932)77-34-06  
Ижевск (3412)26-03-58  
Иркутск (395)279-98-46  
Казань (843)206-01-48  
Калининград (4012)72-03-81  
Калуга (4842)92-23-67  
Кемерово (3842)65-04-62  
Киров (8332)68-02-04  
Коломна (4966)23-41-49  
Кострома (4942)77-07-48  
Краснодар (861)203-40-90  
Красноярск (391)204-63-61  
Курск (4712)77-13-04  
Курган (3522)50-90-47  
Липецк (4742)52-20-81

Казахстан +7(7172)727-132

Магнитогорск (3519)55-03-13  
Москва (495)268-04-70  
Мурманск (8152)59-64-93  
Набережные Челны (8552)20-53-41  
Нижний Новгород (831)429-08-12  
Новокузнецк (3843)20-46-81  
Новосибирск (383)227-86-73  
Омск (3812)21-46-40  
Орел (4862)44-53-42  
Оренбург (3532)37-68-04  
Пенза (8412)22-31-16  
Петрозаводск (8142)55-98-37  
Псков (8112)59-10-37  
Пермь (342)205-81-47

Киргизия +996(312)96-26-47

Ростов-на-Дону (863)308-18-15  
Рязань (4912)46-61-64  
Самара (846)206-03-16  
Саранск (8342)22-96-24  
Санкт-Петербург (812)309-46-40  
Саратов (845)249-38-78  
Севастополь (8692)22-31-93  
Симферополь (3652)67-13-56  
Смоленск (4812)29-41-54  
Сочи (862)225-72-31  
Ставрополь (8652)20-65-13  
Сургут (3462)77-98-35  
Сыктывкар (8212)25-95-17  
Тамбов (4752)50-40-97  
Тверь (4822)63-31-35

Тольятти (8482)63-91-07  
Томск (3822)98-41-53  
Тула (4872)33-79-87  
Тюмень (3452)66-21-18  
Ульяновск (8422)24-23-59  
Улан-Удэ (3012)59-97-51  
Уфа (347)229-48-12  
Хабаровск (4212)92-98-04  
Чебоксары (8352)28-53-07  
Челябинск (351)202-03-61  
Череповец (8202)49-02-64  
Чита (3022)38-34-83  
Якутск (4112)23-90-97  
Ярославль (4852)69-52-93